

CENTRE FOR APPLIED MACROECONOMIC ANALYSIS

The Australian National University



CAMA Working Paper Series

January, 2006

INFLEXIBILITY OF INFLATION TARGETING REVISITED: MODELING THE “ANCHORING” EFFECT

Jan Libich

La Trobe University

The Australian National University

CAMA Working Paper 2/2006

<http://cama.anu.edu.au>

Inflexibility of Inflation Targeting Revisited:

Modelling the ‘Anchoring’ Effect *

Jan Libich

La Trobe University and CAMA

First Version: February 2005

This Version: January 2006

* I am grateful to Glenn Otto for his insightful comments and suggestions. I would also like to thank Don Brash, Viv Hall, Andrew Hughes Hallett, Paolo Giordani, Jonathan Kearns, Marion Kohler, David Leslie, Martin Melecky, Ben McCallum, Jeff Sheen, the participants of the ZEI Summer School on Monetary Theory and Policy, Bonn, and seminars at Victoria University of Wellington, and the Reserve Bank of New Zealand for their feedback and discussions. All remaining errors are mine. Please address correspondence to Jan Libich, La Trobe University, School of Business, Melbourne, Victoria, 3086, Australia. Email: j.libich@latrobe.edu.au.

Abstract

Opponents of inflation targeting have argued that a commitment to a numerical inflation target reduces policy's stabilization flexibility – increasing output volatility under supply shocks. Using a novel game theoretic approach our paper demonstrates that this claim may fail to account for the ‘anchoring’ effect of explicit targets on expectations and wages. Under a credible *long-term* inflation target and costly acquiring information/wage resetting the public may find it optimal to ‘look-through’ shocks. This makes policymaker's *short-term* interest rate instrument more effective in output stabilization giving it greater leverage over the real rate. As a consequence, the variability trade-off is improved, i.e. volatility of both inflation and output is reduced in equilibrium. Our analysis thus adds another dimension to the ‘rule vs. discretion debate’ by showing that a long-run rule may be compatible with (and in fact enhance the effectiveness of) short-run discretion. We conclude by showing that our results are consistent with several empirical findings of the literature.

Keywords: inflation targeting, stabilization flexibility, output volatility, commitment, rigidity, asynchronous move games, rule, discretion

JEL classification: E42, E61, C72

‘The extent to which inflation targeting regimes impair central bank flexibility is a matter of professional dispute.’

McCallum (2003), ‘Inflation Targeting for the United States’, Shadow Open Market Committee, available at <http://www.somc.rochester.edu/May03/McCallum.pdf>

‘Inflation targeting, even without imposing a rigid rule, would unduly reduce the flexibility of the Fed to respond to new economic developments in an uncertain world.’

Rudebusch and Walsh (1998), ‘U.S. Inflation Targeting: Pro and Con’, FRBSF Economic Letter, 98-18

‘The argument that inflation targeting might increase output fluctuations can be turned on its head. I would argue that inflation targeting can actually make it easier to reduce output fluctuations and probably has done so. First, the presence of an inflation target provides an effective nominal anchor...’

Mishkin (2004), ‘Why the Federal Reserve Should Adopt Inflation Targeting’, International Finance’, Volume 7, Issue 1

1 Introduction

The 1990s was a decade of central banking reform. Most significantly, a number of countries have followed New Zealand's lead and adopted a regime known as inflation targeting (hereafter IT, for extensive treatments see Bernanke et al. (1999), Svensson (1999), Blejer et al. (2000), Mishkin and Schmidt-Hebbel (2001), Truman (2003)). Since its emergence, IT has generated an ever-increasing amount of research discussing its pros and cons.¹

This paper focuses specifically on one advantage and one disadvantage identified in this literature that are associated with IT's defining feature - policymaker's explicit (legally grounded) commitment to a numerical inflation target. On one hand, it has been argued that numerical targets are beneficial as they better *anchor* inflation expectations and wages. On the other, it has been believed that such commitment constrains policymaker's *stabilization flexibility* and leads to higher output volatility, which is inconsistent with monetary policy's 'dual mandate' (of achieving output stability *as well* as price stability).² Our paper contributes to the IT debate by (i) explicitly modelling these two mechanisms and (ii) establishing a link between them unnoticed in the literature that may be crucial in assessing the regime's desirability.

The 'inflexibility view' (see e.g. Kohn (2003), Friedman (2004)) seems to be grounded in the following simple intuition due to Rogoff (1985). Let the following be the policymaker's

¹ 'The IT debate' (borrowing the title of Bernanke and Woodford (2005)) seems to be heating up with IT's advocates gaining an edge. This can be documented by the number of prominent academics and central bankers arguing in favour of explicit inflation targets for the U.S., e.g. Bernanke (2003), Goodfriend (2003), McCallum (2003), Mishkin (2004), Lacker (2005) and many others.

² The meaning of 'stabilization flexibility' has not been precisely defined in the literature. We will use it in the rather loose sense of Bernanke (2003) as the ability 'to choose the best policies in the future' in terms of output and inflation stabilization. It has been forcefully argued that even central banks with a legal 'unitary' or 'hierarchical' mandate (in which price stability is the sole/primary goal) attempt to stabilize output in practice, see e.g. Cecchetti and Ehrmann (1999) or Kuttner (2004).

one-period objective function: $U_t = -\alpha(x_t - k)^2 - \pi_t^2$, where x , π , $\alpha \geq 0$, $k \geq 0$, and t denote the output gap, inflation, their relative weight, the output gap target, and time respectively. A common way to think about IT in such standard setting is *lower* α which Rogoff coined the ‘conservative’ central banker. It is straightforward to show that in the presence of aggregate supply shocks lower α indeed translates into higher output volatility.³ However, a number of researchers, most notably Svensson (1999), have argued that while IT does mean ‘constrained discretion’, the regime does not compromise stabilization flexibility if inflation targets are specified as a medium to long-term objective (the case in most industrial countries). Such ‘flexible IT’ then, it is argued, only affects the *trend* level of inflation, not the volatility of targeted variables.⁴

We go a step further and show that policy’s flexibility may in fact *increase* under IT. This has not yet been explicitly shown in the literature, only Bernanke (2003), Goodfriend (2003) and Mishkin (2004) argue that the extra credibility gained by IT may enable central banks to reduce the interest rate more aggressively in response to cost-push shocks without ‘upsetting’ inflation expectations, which reduces output volatility. Our finding is similar in the sense that a long-run inflation target better anchors public’s behaviour which makes the policymaker’s interest rate instrument more effective in stabilization. However, our result differs in that improved output stabilization may be achieved by a *less* aggressive equilibrium response

³ Therefore, α is commonly referred to as the flexibility parameter, Svensson (1997a) and Cukierman and Gerlach (2003). The extreme case of $\alpha = 0$ denotes ‘strict IT’ in the language of Svensson (1999) and ‘inflation nutters’ ala King (1998).

⁴ This will be apparent in equation (6). An alternative source of the inflexibility view may be the transparency literature that has argued that transparency is likely to limit policymaker’s flexibility to use private information in stabilization (e.g. Cukierman and Meltzer (1986), Garfinkel and Oh (1995), Cukierman and Lippi (1999), Faust and Svensson (2001), (2002), and Jensen (2002)). It should be said, however, that all these models refer to ‘economic’ transparency (publishing information about shocks and forecasts), not ‘political’ (goal) transparency (explicit inflation targets), for the distinction see Eijffinger and Geraats (2002) or Hughes Hallett and Viegi (2003).

(smaller change in the interest rate). If interest rate volatility is disliked, see e.g. Woodford (1999), (2003), this constitutes an additional advantage of IT.

Our paper is not the first to derive this result. Orphanides and Williams (2003) model public's learning about policymaker's inflation target and similarly find that explicit numerical targets through their emphasis on price stability reduce the 'responsiveness' of expectations to observed inflation and hence improve the *variability tradeoff*. Our insights are further consistent with Cubitt (1992); he shows that public's pre-commitment may be exploited by the policymaker to better stabilize output. We later extensively discuss the existing empirical evidence related to our results and show that while it is not conclusive there exists fair support for all our findings.

1.1 Methodology

Our model is a combination of the canonical New Keynesian framework as presented in Clarida, Gali and Gertler (1999) and the seminal work of Rogoff (1985). The analysis is broken up into two interconnected stages. The first focuses on the medium-long-run (LR) and examines the *trend* levels of important variables (in the spirit of the Barro-Gordon literature). The second, short-run (SR), studies the effects of shocks that cause *deviations* from the trend and the need to fine-tune the economy (similarly to the New Keynesian literature).

This dichotomy points to a crucial aspect of our analysis that has not been sufficiently investigated - the fact that the policymaker has *two* instruments for two horizons. We show that the policymaker can affect the trend (average) level of inflation through its LR instrument, the (level and explicitness of the) inflation target, whereas its SR instrument, the

interest rate, can be used to minimize inflation and output volatility around the trend.⁵ The main objective of the paper is therefore examining the interaction between these two instruments, namely the effect of an *explicit commitment* to a LR inflation target on the stabilization flexibility of the SR interest rate instrument. In the terminology of Kydland and Prescott (1977), we examine the impact of a LR ‘rule’ on SR ‘discretion’ and establish a link through *rigidity/anchorness* of wages and expectations.

In order to do so we apply a new game theoretic technique developed in Libich (2004), (2005) that explicitly incorporates both policymaker’s commitment and public’s rigidity into a unified framework. One of the novel aspects is modelling commitment and rigidity via the same game theoretic tool; which takes use of the fact that they ultimately express the same feature: *players’ inability to reconsider their actions every period*.

The macroeconomic literature has long taken notice of various rigidities seeking plausible explanations for some observed phenomena. Empirical research followed the theory and provided convincing micro-level evidence of the stickiness of, among other, prices and wages - for recent surveys see Apel, Friberg and Hallsten (2005) and Bewley (2002) respectively.⁶ Our framework takes rigidity a ‘level up’ and incorporates it in the *timing structure* of games. This generalization of alternating move games (e.g. Maskin and Tirole (1988), Lagunoff and Matsui (1997), Cho and Matsui (2005)) attempts to bridge the gap between the micro-

⁵ The analysis will show that an explicit inflation target deserves to be viewed as an instrument not only because it affects the level of trend inflation but also because it can influence public’s wage setting behaviour in a desirable way. It is important to note, however, that the specification of an inflation target as a medium to long term objective is crucial in our analysis. Our findings only apply to countries in which the target’s horizon is ‘indefinite’ or ‘business cycle’ (the majority of industrial countries), not those with a one-year horizon (most developing or transition countries) or a (two-year) inflation forecast targeting framework of the Bank of England type - see Svensson (1997a). For a summary of the horizons see Mishkin and Schmidt-Hebbel (2001).

⁶ The proposed underlying reason has been the existence of some *cost* associated with either gathering/processing new information or the appropriate adjustment of actions based on this information. For example in price-setting, the latter drives the ‘sticky-price’ New Keynesian model - building on Taylor (1980) and Calvo (1983) - whereas the former underlies the ‘sticky-information’ model of Mankiw and Reis (2002) building on Fischer (1977).

founded models of the economy currently used for monetary policy analysis (in which various rigidities take central stage) and the static rigidity-free game theoretic setup (in which players move *simultaneously each* period) that is implied by the *rational expectations* solution imposed in these very models.⁷

The notion of rigidity we adopt follows Taylor (1979) rather than Calvo (1983) in that it is deterministic – an action m of player j can only be adjusted every r_m^j periods.⁸ Importantly, since rigidity ties the hands of the players it may be interpreted as *commitment*. In contrast to the standard commitment concept used in game theory, our framework enables us to consider *various degrees* of commitment and its endogenous determination.⁹

1.2 Intuition

We first examine the policymaker’s LR commitment choice. This can be interpreted as choosing the ‘explicitness’ of the LR inflation target since the more explicit the target the harder it is (and the longer it takes) to change it. It is shown that the policymaker will choose to give up LR discretion (the ability to reconsider the target every period) and *sufficiently (explicitly)* commit to the target in order to escape the time inconsistency problem and eliminate the *average* inflation bias. However, the degree of such commitment may vary. We then consider the effect of this LR commitment on rigidity/anchorness of wages (and loosely speaking expectations), i.e. the frequency with which these are adjusted by the public. It is shown that if revising wages (updating expectations) is costly, public’s

⁷ It is not commonly discussed that using the rational expectation solution imposes an implicit ‘simultaneity’ and ‘flexibility-to-always-move’ assumptions on the timing structure of the moves, i.e. it goes well beyond just assuming rationality.

⁸ Since rigidity lasts for a strictly finite number of periods the Taylor model is ‘commonly regarded as a more realistic depiction of reality than the Calvo model...’ (King and Kurmann (2002)).

⁹ The endogeneity is similar to games with endogenous timing, e.g. Bhaskar (2002).

optimal rigidity will be *increasing* in the degree of the policymaker's LR commitment. Put differently, the stronger the policymaker commits in the LR (the more explicit the inflation target) the longer the wage contracts.

Finally, we study the impact of public's rigidity on the policymaker's stabilization flexibility. This flexibility is shown to be determined by the flexibility of the SR interest rate instrument which is *increasing* in public's rigidity. Intuitively, if expectations/wages do not adjust in response to a shock ('look-through' it in the terminology of Brash (2002)), the policymaker has more leverage over the real interest rate and can better stabilize the economy (both output and inflation), even with a smaller change in the interest rate instrument. In summary, the stronger the policymaker's LR commitment (the more explicit IT), the greater her SR flexibility. Combining these findings implies that IT may reduce output volatility, the opposite of what the sceptics conjecture.

1.3 Additional Results

There are additional results in the paper. Most importantly, it offers an explanation for why some countries have been more explicit in their pursuit of low inflation than others. It finds that there exists substitutability between LR inflation commitment and policymaker's conservativeness in securing credibly low inflation. If we follow the Rogoff (1985) literature and interpret conservativeness as central bank independence this predicts that explicit IT will be pursued most actively by rather 'goal-dependent' central banks. We present convincing empirical support for this prediction based on established indices of independence, transparency and accountability. Further, the analysis offers an explanation for why these institutional features may not have been needed before the 1970s but were imperative afterwards.

The rest of the paper is structured as follows. Section 2 presents the model and the standard game theoretic setup. Section 3 introduces rigidity and commitment in the timing structure of the game. Section 4 examines the LR outcomes whereas section 5 considers the SR outcomes. Section 6 discusses the results, empirical evidence, and some extensions. Section 7 summarizes and concludes.

2 The Model

2.1 The Economy and Players

We follow the popular setting of Clarida, Gali and Gertler (1999) reviving some features from Rogoff (1985) and making several simplifications in order to better expose the intuition. The set of players will be denoted $J = \{p, g\}$ where p is the public and g is the government/(goal-dependent) central banker/policymaker.¹⁰ Throughout, the players are assumed to be rational and have common knowledge of rationality and complete information about the economy and the structure of the game. Further, they do not discount the future.¹¹ Government's one-period preferences are as postulated in the introduction

$$U_t^g = -\alpha(x_t - k)^2 - \pi_t^2 \tag{1}$$

The parameter α expresses (the opposite of) the policymaker's conservativeness in the spirit of Rogoff (1985) and it will further be assumed that $k > 0$.¹²

¹⁰ While central bank goal-independence is not explicitly modeled we will later follow the literature and interpret it in the Rogoff (1985) sense as synonymous to conservativeness. See Hughes Hallett and Libich (2004) for explicit modeling of the government's delegation of monetary policy to an independent central bank.

¹¹ For extensions see Libich (2004) who models the effects of (i) backward-looking expectations and (ii) players' impatience in this framework.

¹² The latter should be thought of as *government's* (rather than central banker's) overambitious output gap target, which may be due to political economy reasons or market distortions such as imperfect competition and taxes. The fact that governments may be tempted to surprise inflate is, we believe, uncontroversial.

The public's one-period utility function is the following

$$U_t^p = -(\pi_t - w_t)^2 \quad (2)$$

where w denotes the rate of change of nominal wages - *current wage inflation* - public's instrument. The intuition of this specification is standard, i.e. the public attempts to correctly *expect* the inflation rate in order to set wages appropriately (for justification based on Fischer-Gray contracts see Canzoneri (1985)). While in a rigidity-free environment the terms wage inflation and expected inflation can be used interchangeably, see e.g. Backus and Driffill (1985), it will become evident that in the presence of public's rigidity these two differ.¹³ The economy is described by two equations, namely a Phillips curve and an 'IS' curve in which - similarly to (2) - expected inflation of the New Keynesian framework is replaced by wage inflation of the Rogoff framework.

$$\pi_t = \lambda x_t + w_t + u_t, \quad u \sim iid(0, \sigma_u^2) \quad (3)$$

$$x_t = -\varphi(i_t - w_t) + g_t, \quad g \sim iid(0, \sigma_g^2) \quad (4)$$

where i is the policymaker's interest rate instrument and λ and φ are positive parameters.¹⁴ This specification allows for two interpretations depending on the timing of wage setting - that will be endogenously determined below. The wages for period t , w_t , may either be set in t (in which case the intuition coincides with the Clarida, Gali and Gertler (1999) framework with no past-dependence) or pre-set in the past (which is similar to the 'sticky-information'

¹³ This is due to our simplifying full information assumption. Nevertheless, the *insights* about public's (rigid) wage setting will also apply to public's (infrequent) updating of *expectations*. Further note that the public's inflation aversion will be incorporated in section 4.

¹⁴ We simplify the Clarida, Gali and Gertler (1999) model in three respects. First, we assume out the 'consumption smoothing' effect of expected output gap on current output gap. While this effect may be small in the real world, see Fuhrer (1997), we later discuss its inclusion. Second, we assume out serial correlation in shocks. It will later be discussed that our qualitative results are robust to this simplification. Third, since the players are assumed not to discount the future, the underlying discount factor of households - the parameter on w_t in (3) - is similarly set to unity.

framework of Mankiw and Reis (2002)). However, we stress that in either case the private sector is forward-looking, i.e. a possible past-dependence is *not* due to adaptive expectations as in e.g. Svensson (1997b) or Ball (1997).

2.2 The Standard (Rigidity-free) Game

The policy outcomes have been, at least since Barro and Gordon (1983a, 1983b), commonly studied in the framework of an (infinitely) repeated game. Under discretion players' instruments are chosen *simultaneously* at *each* period t .¹⁵ In such case the policymaker takes expected/wage inflation as given and repeatedly solves a static optimization problem; it selects the optimal values of π_t and x_t and sets its instrument i_t that ensures these outcomes. Abstracting from reputational considerations, i.e. restricting our attention to Markov perfect equilibria, from the usual Lagrangian we obtain the familiar optimality condition (for details see Clarida, Gali and Gertler (1999)).

$$\pi_t = -\frac{\alpha}{\lambda} x_t + k \tag{5}$$

Substituting (5) into the Phillips curve yields equilibrium values (denoted by 'star' throughout) of inflation and output gap

$$\pi_t^* = k + \frac{\alpha}{\lambda^2} u_t \text{ and } x_t^* = -\frac{1}{\lambda} u_t \tag{6}$$

Note that shocks are stationary with zero mean - implying that they do not affect the trend/average/LR values (these three terms will be used interchangeably and denoted by 'bar'). As the trend and deviations are independent the policymaker can, in some period t in

¹⁵ As mentioned above the rational expectations assumption of the New Keynesian literature is equivalent to this repeated game; it implicitly assumes that expectations can be readjusted every period.

which a supply shock occurs, *consistently* pursue a certain level of LR inflation, $\bar{\pi}_t$ (i.e. be committed to a LR inflation target), but choose a *different* level of SR inflation, $\pi_t \neq \bar{\pi}_t$, that optimally maximizes its objective function according to (5). To demonstrate the independence of LR and SR (which will enable us to view the inflation target as another instrument), (6) with $\bar{u} = 0$ yields the equilibrium *trend* levels

$$\bar{\pi}^* = k \text{ and } \bar{x}^* = 0 \tag{7}$$

While the latter is not controversial – there exists a wide consensus and empirical support for Friedman’s natural rate hypothesis – the former is. Under $k > 0$ we have the famous *inflation bias* result.¹⁶ Unlike the rest of the remedies in the literature that restore to lowering k or α to zero (or reputation building) we will show that in the rigid world under some circumstances the average bias disappears, $\bar{\pi}^* = 0$, even if $\alpha, k > 0$. We will later argue that the derived conditions are satisfied in industrial countries drawing a link to the observed trend towards central bank independence, transparency, and accountability.

3 Introducing Commitment and Rigidity

The treatment here is a simplified version of the framework proposed in Libich (2004), (2005) which brings together three distinct literatures. Building on the staggered-pricing macro literature, e.g. Fischer (1977), Taylor (1979), and Calvo (1983) the framework incorporates rigidity into the *timing structure* of games. This is done by generalizing the asynchronous (alternating) move setups of Maskin and Tirole (1988) and Lagunoff and Matsui (1997) also drawing on the intuition of games with endogenous timing, e.g. Bhaskar (2002), and Huck,

¹⁶ It is important to note, however, that Cukierman (1999), Ruge-Murcia (2003), (2004) and Cukierman and Gerlach (2003) recently showed that even if the output target is *not* above the natural rate, i.e. under $k = 0$, inflation bias may still exist. This happens if policymaker’s preferences are asymmetric and positive output deviations from the expected natural rate have less weight than negative ones.

Muller and Normann (2002).¹⁷ It is shown that since rigidity draws a link between successive periods and ties the hands of players, it also provides a new concept of *commitment*.

Definition 1: *Player j 's instrument m 's **rigidity/commitment** (denoted r_m^j) expresses the number of periods for which the respective action is fixed.*

Denoting $j \in J = \{g, p\}$ and $m \in M = \{\bar{\pi}, i, w\}$ it follows that the parameters $r_{\bar{\pi}}^g$, r_i^g , and r^p are *integers* interpreted as the policymaker's *LR (inflation) commitment*, the policymaker's *SR (interest-rate) commitment*, and public's *wage rigidity* respectively (we will use the latter without the subscript).¹⁸ It is straightforward to see that our framework is a generalization of previous game theoretic approaches. First, in standard repeated games players' actions are 'fixed' for one period from t to $t+1$, i.e. $r^j = 1, \forall j$ (e.g. the Barro-Gordon monetary policy game). This can be considered the case of 'no rigidity' as the length of t may be infinitesimally short and following Kydland and Prescott (1977) we will refer to $r_m^g = 1$ as (LR or SR) discretion. Second, in alternating move games we commonly have $r^j = 2, \forall j$ (e.g. Maskin and Tirole (1988, Lagunoff and Matsui (1997)). Third, games using the standard notion of commitment (implicitly) assume $r^j \rightarrow \infty$, i.e. the commitment binds throughout.¹⁹

¹⁷ For motivation and the related literature see Libich (2004), (2005).

¹⁸ We would like to stress that the degree of LR commitment does *not* refer to how fast inflation is supposed to come back to the target after a deviation - the targeting horizon is the LR independently of $r_{\bar{\pi}}^g$. Instead, from the definition $r_{\bar{\pi}}^g$ literally refers to the *length* of the commitment expressed as the number of periods for which it cannot be reconsidered or abandoned. As a real world example, the 1989 Reserve Bank of New Zealand Act states that the inflation target may only be changed in a Policy Target Agreement between the Minister of Finance and the Governor and this can only be done on pre-specified occasions (e.g. when a new Governor is appointed). This implies that $r_{\bar{\pi}}^g$ is interpretable as the 'explicitness' of IT. The more explicitly is the inflation target grounded in the central banking legislation the more rigid the policymaker is in its re-setting. It should further be noted that the absence of a legislated numerical target may not necessarily imply $r_{\bar{\pi}}^g = 1$; it has been argued that many countries pursue an inflation target *implicitly* (including the U.S., see e.g. Goodfriend (2003), or the Bundesbank and the Swiss National Bank in the 1980s, see Bernanke et al. (1999)).

¹⁹ The latter is true of most game theoretic applications including the *strict instrument* rules considered in Barro and Gordon (1983a, 1983b), $\pi_t = 0, \forall t$. In contrast, this does not apply to the commitment solution used in the New

The framework adopts all the main features of the above papers. First, we assume rigidity to be *deterministic* and *observable* by the players.²⁰ Depending on the underlying circumstances, r_m^j may be determined either exogenously or endogenously (as players' optimal choice). In either case all r_m^j are *constant* throughout each game. Second, in period 1 players move *all their instruments* $m \in M$ *simultaneously* which expresses the 'initial' uncertainty. Then players set their instruments every r_m^j periods. Third, opponent's preceding periods' moves can be *observed*. This implies that under *relative* commitment/rigidity the Cournot and Stackelberg scenarios are combined.

Definition 2: An *unrepeated rigid game* is a one-shot dynamic game that starts with a simultaneous move of all actions and finishes just before another such simultaneous move is made, i.e. after C periods where C denotes the 'least common multiple' of all instruments' rigidities, $r_m^j, \forall j, m$ (see an example in Figure 1).

Figure 1: $r_{\bar{\pi}}^g = 3, r^p = 2, r_i^g = 1 \Rightarrow C = 6$

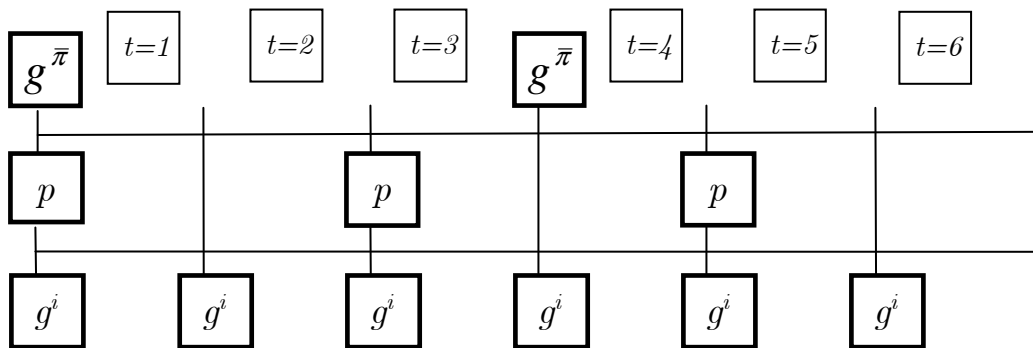

Keynesian literature popularized by Woodford (1999) and Clarida, Gali and Gertler (1999) (see also Dennis and Soderstrom (2002) and McCallum and Nelson (2004b)) that yields a targeting rule (for the distinction see e.g Svensson (1999)). Such a rule commits the policymaker to choose a state contingent *sequence* for π_{t+i} and x_{t+i} , i.e. pursue an optimality condition such as (5). Nevertheless, it still allows her to react to disturbances *every* period and can therefore be viewed as a form of our discretionary $r_i^g = 1$ (which will be discussed later in more detail).

²⁰ We find the Taylor (1980) deterministic feature a more natural way to think about rigidity than the Calvo (1983) probabilistic setting (that the literature has embraced primarily for algebraic convenience). This is true especially for wage rigidity where r^p expresses the pre-determined frequency of wage negotiations. Nevertheless, probabilistic rigidity ala Calvo will be developed in our future work (d'Artignes and Vignolo (2005) have already done so in the stochastic evolutionary model by Kandori, Mailath and Rob (1993)).

3.1 Determination of Commitment/Rigidity

We consider the following assumptions that seem most realistic in the central banking context. First, we exogenously set $r_i^s = 1$ (i.e. the interest rate is adjusted every period in a discretionary manner) to express that the interest rate instrument is flexible relative to the other instruments. This implicitly assumes that r_i^s is *not* directly affected by $r_{\bar{\pi}}^s$ which follows from the fact that the LR commitment is specified over trend level of inflation. Second, $r_{\bar{\pi}}^s$ and r^p are endogenous. At the beginning of the game, the policymaker first chooses the degree of LR commitment (the explicitness of IT), $r_{\bar{\pi}}^s$, and only then, observing the policymaker's choice, the public selects the degree of its rigidity, r^p (the frequency of wage negotiation). These decisions are observable in period 1 by their opponents as well as the following cost structure.

We assume that the LR commitment is costless for the policymaker. This is because the main potential ‘inflexibility’ cost of IT spelled out by the literature is explicitly studied below. In contrast, wage negotiation is costly for the public. Using the words of Mankiw and Reis (2002), there are costs of ‘changing wage contracts and information-gathering, decision making, negotiation and communication’. Therefore, we assume the public’s ‘flexibility cost’ to be a constant *per-period* fee, c_F , that is a decreasing function of the selected wage rigidity level. For convenience, we postulate $c_F = \frac{c_f}{r^p}$ where $c_f > 0$. We can now summarize the timing of the game.

1. The policymaker selects $r_{\bar{\pi}}^s$ and, observing it, the public chooses r^p . Both choices apply throughout the whole game.

2. At the beginning of every period t there is a realization of the shocks, u_t and g_t , observable by the players.²¹
3. In period 1 the players simultaneously set $\bar{\pi}$, i , and w . These actions can then be reset every $r_{\bar{\pi}}^s$, r_i^s , and r^p periods respectively.

To better communicate the intuition of the rigid environment we will study two versions of the game labeled the ‘LR game’ and the ‘SR game’. The LR game will examine the game under the assumption of no shocks, $\forall t, u_t, g_t = 0$, to focus on the trend outcomes. In contrast, the SR game will feature shocks and study the resulting deviations from the trend. While the inflation and output values from the SR game will not equal their LR game counterparts in the presence of supply shocks, the trend values *will* since they are not affected by shocks (see (7)). Further, it will be shown that the LR game findings in terms of players’ optimal choices of $r_{\bar{\pi}}^s$ and r^p also hold in the SR game.

4 The LR Game

In a shock-free environment current inflation always equals trend inflation, $\pi_t = \bar{\pi}_t, \forall t$. As the interest of the LR game lies in the trend outcomes and the policymaker’s interest rate instrument setting becomes trivial, it will be suppressed in this section and only the $r_{\bar{\pi}}^s$, r^p , $\bar{\pi}_t$ and w_t choices will be focused on. We will denote the latter \bar{w}_t (and the resulting output gap \bar{x}_t) to indicate that these variables should also be, in the absence of shocks, interpreted as trend values. The Kydland-Prescott debate then has a new flavour; the LR game not only

²¹ This follows the standard assumption of the New Keynesian framework, e.g. Clarida, Gali and Gertler (1999). The case in which the public cannot perfectly observe the shocks and the policymaker has private information about them has been the focus of the ‘transparency’ literature, see e.g. Cukierman and Meltzer (1986), Garfinkel and Oh (1995), Cukierman (1999), Jensen (2002), Faust and Svensson (2001), (2002), and Demertzis and Hughes Hallett (2003).

examines time consistency and credibility of low inflation but also of a low trend-inflation *target*. Furthermore, it studies endogenous determination of the target's *explicitness* (rigidity) and its effect on the target's credibility.

For expositional purposes we make four simplifying assumptions. First, following the game theoretic literature (e.g. Cho and Matsui (2005)), we only depict two levels of the LR inflation target, namely $\bar{\pi} = 0$ and $\bar{\pi} = \bar{\pi}^*$. Equation (7) implies that this restricts the action space to $\bar{\pi} = \bar{w} = \{0, k\}$.²² We will refer to these levels as low and high and denote them by superscripts L and H respectively. Second, unlike Libich (2004) we will focus our attention solely on the intuitive special case in which relative commitment/rigidity is an integer, i.e. either $r_{\bar{\pi}}^s = nr^p$ or $r^p = nr_{\bar{\pi}}^s$ where n is an integer. This assumption implies $C = r_{\bar{\pi}}^s$ or $C = r^p$ and means that only the more committed/rigid player in the LR game will experience Stackelberg leadership (Figures 2-3 present examples of the game using a timeline and an extensive form).²³

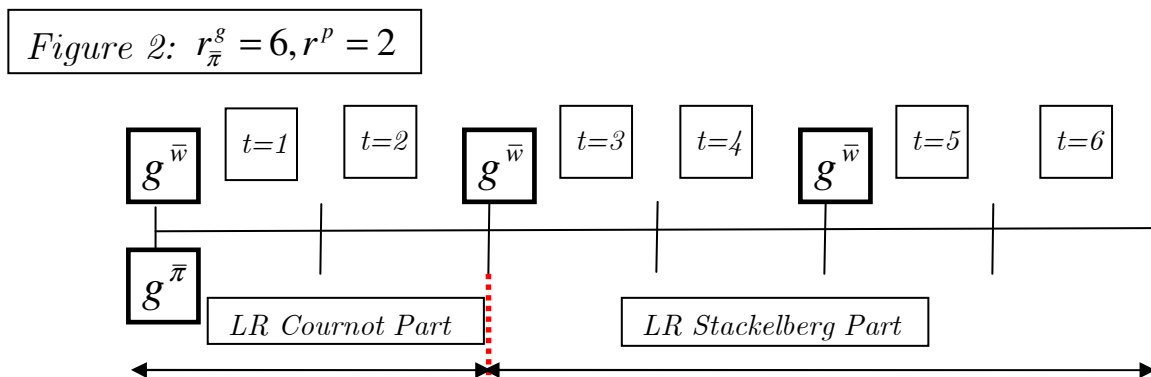

²² If different values are selected the results differ quantitatively but their qualitative nature is intact.

²³ Without this restriction players' rigid periods may overlap so both players may experience Stackelberg leadership in trends (as in Figure 1). See Libich (2004) who shows that the qualitative findings of these two cases are identical and the depicted special case is therefore representative of the general framework. Also note that the restriction allows us to collapse public's second and third moves in Figure 3 into one - they are made under the same circumstances.

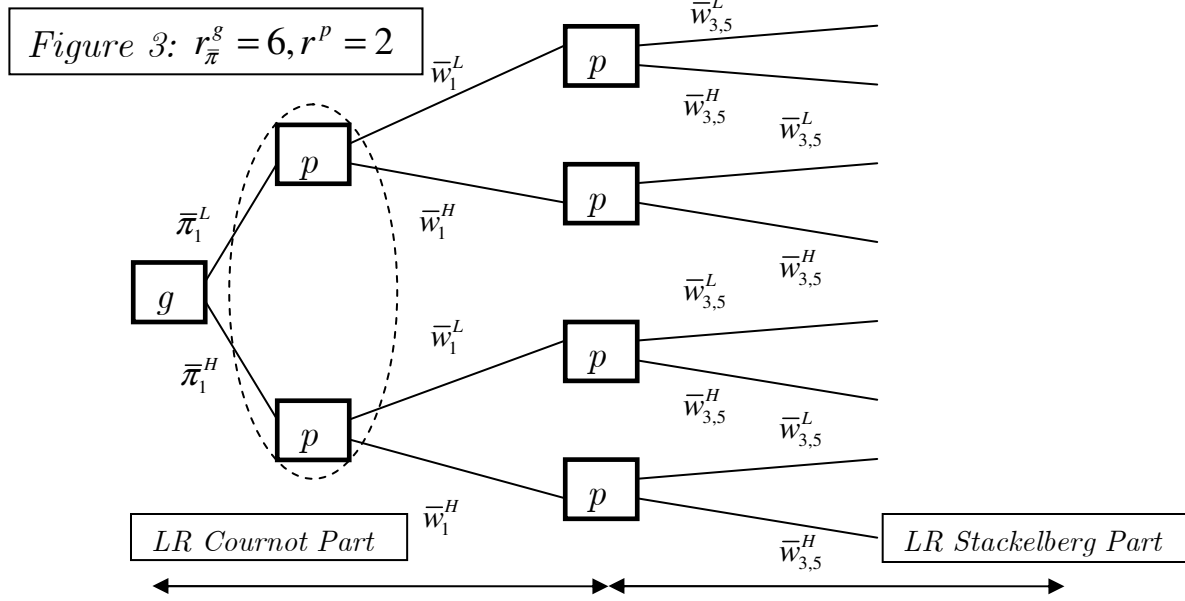

Third, we assume that like the policymaker, the public is averse to LR inflation (for the common reasons such as menu costs, shoe leather costs, fixed income etc, see e.g. Romer and Romer (1997)). Any positive trend inflation, $\bar{\pi} > 0$, is assumed to incur a per-period cost to the public, $c_{\bar{\pi}}$. To impose that the cost is not trivial (see McCallum and Nelson (2004a)) we restrict it to be greater than public's maximal one-period flexibility cost, $c_{\bar{\pi}} > c_f$. Figure 4 presents the stage game payoff matrix (with $c_{\bar{\pi}} = 1$ set for illustration).

Figure 4

		Public	
		\bar{w}^L	\bar{w}^H
Policymaker	$\bar{\pi}^L$	$a = -\alpha, 0$	$b = -4\alpha, -1$
	$\bar{\pi}^H$	$c = -1, -2$	$d = -\alpha - 1, -1$

We only consider $\alpha > 1$ for which there still exists a time inconsistency problem in our truncated game; this is however a purely technical restriction that should not be interpreted as imposition of a 'liberal' policymaker. Let us refer to $(\bar{\pi}^H, \bar{w}^H)$ as the 'Kydland-Prescott' outcome and $(\bar{\pi}^L, \bar{w}^L)$ as the 'Ramsey' outcome (to indicate its Pareto superiority). The rigid game can be solved by subgame perfection. In the solution we focus on *Markov perfect*

equilibria, i.e. the unrepeated rigid game. We can now propose our first set of results which the next section shows to obtain even in the SR game in which disturbances are present.

Proposition 1: (i) *The policymaker will give up LR discretion and sufficiently explicitly commit its LR instrument.* (ii) *Low trend inflation will be time consistent.* (iii) *Wage rigidity will be weakly increasing in the degree of LR commitment (explicitness of IT).*

Proof: Let us start with the standard Barro-Gordon case $r_{\bar{\pi}}^s = r^p$. From Payoffs in Figure 4 we know that the ‘Kydlund-Prescott’ outcome obtains throughout, $\forall t, (\bar{w}_t^H)^*, (\bar{\pi}_t^H)^*$. It is straightforward to show that the same outcome holds under $r_{\bar{\pi}}^s < r^p$. The policymaker’s temptation to surprise inflate is then even greater due to the potentially longer lasting output gain. However, under $r_{\bar{\pi}}^s > r^p$ the time-inconsistency result may no longer obtain. If the policymaker’s LR commitment is *sufficiently* greater than public’s rigidity, her temptation (and the inflation bias) will be eliminated. This is because in such case public’s ‘punishment’, i.e. the post-inflating period of high wages, will be long enough to offset the possible output gain from surprise inflating.²⁴

Using backwards induction, under $r_{\bar{\pi}}^s > r^p$ public’s optimal wage throughout the Stackelberg part will be the best response to government’s Cournot move, $\bar{w}_{r_{\bar{\pi}}^s > r^p}^* = b(\bar{\pi}_1)$ where $b(\cdot)$ will denote the best response. Further, from (2), complete information, and the public’s rationality we know that $\bar{w}_1^* = b(\bar{\pi}_1^*)$. It follows that a low inflation target will be *time consistent* if it is the best response to low (trend) wage inflation, $\bar{\pi}_1^L = b(\bar{w}_1^L)$, which is guaranteed by the following condition

$$r_{\bar{\pi}}^s a \geq r^p c + (r_{\bar{\pi}}^s - r^p) d \tag{8}$$

²⁴ Note that unlike in Barro and Gordon (1983a, 1983b), the punishment in the rigid world is not arbitrary but it is public’s *optimal* play and its length is uniquely determined by players’ commitment/rigidity.

where a , c , and d are the payoffs of Figure 4 (in their general form). The RHS of equation (8) expresses the fact that if the policymaker plays $\bar{\pi}_1^H$ and manages to surprise the public (gaining a c payoff for r^p periods) then in period $t = r^p + 1$, the public switches to $\bar{w}_{r^p+1}^H$ which punishes the policymaker (with a d payoff) for the rest of the unrepeated game, $(r_\pi^s - r^p)$ periods. Rearranging and substituting in the respective values yields

$$r_\pi^s \geq \alpha r^p \quad (9)$$

This implies that to eliminate the time-inconsistency problem the inflation target must be sufficiently rigid (explicit) relative to wages. Let us now examine whether this condition ensures that the Ramsey outcome is a subgame perfect Nash equilibrium (SPNE) and whether it is unique. For this to be the case (i.e. for the ‘Kydland-Prescott’ outcome to fail to constitute a SPNE) $\bar{\pi}_1^L$ must be a weakly dominant strategy, thus it is also required that $\bar{\pi}_1^L = b(\bar{w}_1^H)$. The following condition ensures this

$$r^p b + (r_\pi^s - r^p) a \geq r_\pi^s d \quad (10)$$

The LHS indicates that even if the low inflation target initially ‘lacks credibility’ and is accompanied by high wage inflation the policymaker will stick to it for which it will be rewarded by public’s switching to low wages after r^p periods. Rearranging yields

$$r_\pi^s \geq 3\alpha r^p \quad (11)$$

The condition in (11) is stronger than the one in (9) implying that if LR commitment is in the interval $r_\pi^s = (\alpha r^p, 3\alpha r^p)$ there exist two pure strategy SPNE (and one in mixed strategies). Both players have, due to their inflation aversion, an incentive to alter their r_π^s and r^p in order to satisfy (11) and achieve the Ramsey outcome. The policymaker tends to *increase* its LR commitment (make the inflation target more explicit) whereas the public has an incentive to *reduce* its rigidity by more frequently revising wages (recall the assumed

$c_{\bar{\pi}} > c_f$). However, due to $c_f > 0$ public's choice of r^p will be weakly increasing in $r_{\bar{\pi}}^g$. To *surely* secure the Ramsey outcome (avoid the region of multiple equilibria) the policymaker commits sufficiently, $(r_{\bar{\pi}}^g)^* \geq 3\alpha$ and the public then sets $(r^p)^* = r_{\bar{\pi}}^g / 3\alpha$ to minimize its flexibility cost but ensure (11) holds. This implies, $\forall t$, $(\bar{\pi}_t^L)^*$, $(\bar{w}_t^L)^*$, and $\bar{x}_t^* = 0$ and completes the proof.²⁵

There are three other implications of our LR game that we find worth noting. We will only briefly report them as their thorough treatment is beyond the scope of this paper.

Observation 1: *The policymaker's LR commitment and conservativeness are substitutes in securing credibly low inflation in equilibrium.*

This can be seen from (9) and (11) in which the necessary $r_{\bar{\pi}}^g$ is positively related to α .²⁶ A less conservative policymaker needs to commit more strongly to secure the Ramsey outcome which may explain why some countries have been more explicit in formulation of their price stability objective than others. It was discussed above that conservativeness can be interpreted as central bank independence whereas LR commitment as the explicitness of IT. Proposition 1 and Observation 1 then imply several testable implications that all seem to be consistent with the real world and previous empirical findings of the literature. First, a

²⁵ A few issues should be noted. First, the assumed restriction $r_{\bar{\pi}}^g = nr^p$ still has to hold here so $(r^p)^*$ will be the highest integer lower or equal to the above stated $r_{\bar{\pi}}^g / 3\alpha$ (note that the public could perhaps choose a value of $r_{\bar{\pi}}^g / \alpha$ to minimize the flexibility cost but since this would generate multiple equilibria we will further assume it not to be the case, i.e. we consider sufficient rather than necessary conditions). Second, the equilibrium values would differ with alternative restriction on the action set $\bar{\pi}$ but the qualitative results would be unchanged, see Libich (2004) for several alternative settings.

²⁶ In addition to the Rogoff (1985) interpretation as the parameter α , policymaker's conservativeness can be interpreted in two other ways; as related to the parameter k and/or policymaker's discount factor. It is interesting to note that both of these modifications are consistent with our setting. Libich (2004) examines players' discounting and shows that $\bar{r}_{\bar{\pi}}^g$ is also an increasing function of policymaker's impatience. Further, in a slightly altered setting $\bar{r}_{\bar{\pi}}^g$ is also an increasing function of k .

number of empirical studies found inflation to be decreasing in central bank independence, e.g. Grilli, Masciandaro and Tabellini (1991), Cukierman, Webb and Neyapti (1992), Alesina and Summers (1993), Eijffinger and Schaling (1993), and Eijffinger, Hoerberichts and Schaling (1998). Second, Briault, Haldane and King (1997) show that accountability, too, is associated with low inflation and Chortareas, Stasavage and Sterne (2002) report the same to be true for transparency. Third, Debelle (1997) finds explicit inflation targeting to improve credibility. Finally and perhaps most surprisingly, Briault, Haldane and King (1997), de Haan, Amtenbrink and Eijffinger (1999) and Sousa (2002) report a negative correlation between (goal) independence and accountability (see Figure 5).

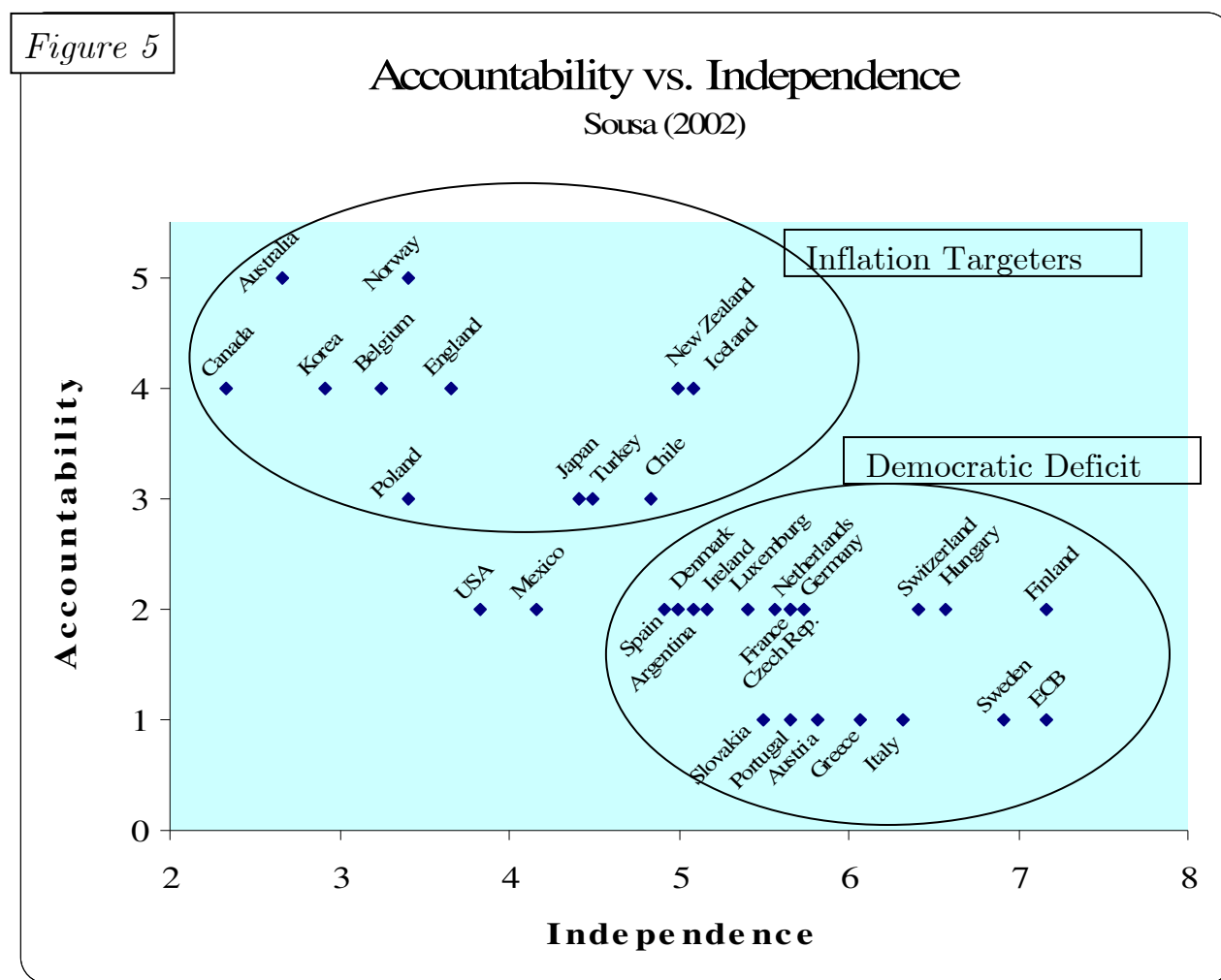

Source: Sousa (2002), see Appendix for details on the criteria, countries, and scores. The correlation coefficient equals -0.78 ($t=-6.94$).

This finding has been viewed as undesirable since the bottom right hand corner countries feature a ‘democratic deficit’.²⁷ The explanation derived in our model is in line with the result of Schaling and Nolan (1998) and the hypothesis of Briault, Haldane and King (1997): ‘*The negative correlation ... suggests that accountability and transparency may have served as (partial) substitutes for independence...*’. For welfare consequences and implications for optimal timing of reform see Hughes Hallett and Libich (2004) in which a comparable result is derived through a different avenue (by explicitly incorporating independence, accountability and transparency in the Barro-Gordon model).

Observation 2: *Initial conditions matter. After a high inflation period a stronger LR commitment may be necessary to ensure the Ramsey outcome in equilibrium.*

We have shown that under some combinations of LR commitment and wage rigidity there exist multiple SPNE. In such case the outcome is likely to depend on the past, i.e. players will continue playing the current SPNE.²⁸ Therefore a certain degree of LR commitment (and/or central bank conservativeness) that may be sufficient in a low inflation environment may be insufficient in the aftermath of a prolonged inflationary period. Note that this is true in our model even under a purely forward-looking public, i.e. not due to adaptive expectations. This may perhaps help explain why institutional arrangements such as a transparent and accounted for inflation target and central bank independence may not have

²⁷ If we only use the ‘focus on price stability’ criterion that is arguable a closer proxy for conservativeness the finding remains unchanged. The same is true in the comprehensive dataset by Fry et al. (2000); both target-independence and the length of term in office are negatively correlated with punishment procedures (that apply if targets are missed or must be changed) in both industrial and transition countries.

²⁸ Nash equilibrium is by construction a state in which players do not have a tendency to deviate.

been needed before the 1970s to ensure credibly low inflation but were imperative afterwards.²⁹

Observation 3: *A sufficient degree of LR commitment ensures that the policymaker behaves ‘as if’ her output gap target is zero, $k=0$.*

A number of authors, e.g. McCallum (1997) and Blinder (1997), argue that a simple recognition of the fact that $k>0$ leads to undesirable outcomes is sufficient to constrain the policymaker’s behaviour, i.e. she then acts ‘as if’ $k=0$. The question left unanswered is under what circumstances such behaviour will be credible in the eyes of the public. Our analysis offers an answer by showing that a *sufficiently strong* LR commitment, $r_{\bar{\pi}}^g \geq \bar{r}_{\bar{\pi}}^g$, is needed to ensure the credibility of low inflation, i.e. low wages throughout, $(w_t^L)^*, \forall t$.

5 The SR Game

In this section there exist shocks. Despite this we will show that all claims of Proposition 1 hold under shocks (claim iii only for values of σ_u below a certain threshold). As the main focus of this section is on deviations from the trend we start off assuming that (11) is satisfied, $r_{\bar{\pi}}^g > 3\alpha r^p$ (and ex-post show that the policymaker’s optimal LR commitment will indeed be sufficient). We have shown this to lead to $(\bar{\pi})^* = (\bar{w})^* = (\bar{x})^* = 0$ which enables us to only focus on the deviations from the trend, i.e. the i_t and w_t choices. In period 1 players move simultaneously and select i_1 and w_1 taking the rigidities of their instruments into

²⁹ Alternative explanations exist in the literature. First, the existence of the Bretton-Woods system arguably tied the hands of monetary policymakers (perhaps with the exception of the U.S.). Second, the Phillips curve tradeoff and the possibility of exploiting it only become common knowledge among policymakers in the mid 1960s. Last but not the least, some authors offer alternative explanations of the high inflation period that are independent of the time-inconsistency problem, see e.g. Nelson (2005), Orphanides (2003), De Long (1998), and Taylor (1997).

account. Then i can be adjusted every period in a discretionary manner as $r_i^s = 1$ whereas w is renegotiated every $r^p \geq 1$ periods, depending on wage rigidity.

Proposition 2: *Wage rigidity (i) increases the policymaker's stabilization flexibility and (ii) decreases the volatility of both inflation and output.*

Proof: Due to sufficient LR commitment the game is played 'as if' $k=0$, hence the optimality condition in (5) becomes

$$\pi_t = -\frac{\alpha}{\lambda} x_t \quad (12)$$

Wage inflation, w_t , will differ for periods in which wages can be adjusted (Cournot periods, denoted C) and those in which they cannot (Stackelberg periods, S); therefore, we will be studying these two types of periods separately. It follows from (2) that in C periods optimal wages are set as an average of expected inflation over the whole duration of the contract

$$w_t^C = \frac{1}{r^p} \sum_{i=0}^{r^p-1} E_t \pi_{t+i} \quad (13)$$

Substituting this and (12) into the Phillips curve implies the reduced form expressions for Cournot inflation and the output gap. In doing so we use the fact that for all $i=0,1,\dots$ it is

true that $E_t u_{t+i+i} = 0$, from which it follows that $E_t \pi_{t+i+i} = 0$ and therefore $w_t^C = \frac{\pi_t^C}{r^p}$)

$$(\pi_t^C)^* = \frac{\alpha r^p}{\lambda^2 r^p + \alpha(r^p - 1)} u_t \quad \text{and} \quad (x_t^C)^* = -\frac{\lambda r^p}{\lambda^2 r^p + \alpha(r^p - 1)} u_t \quad (14)$$

Under $r^p=1$ all periods are Cournot and the above equations imply, $\forall t, w_t^C = \pi_t^C$,

$\pi_t^C = \frac{\alpha}{\lambda^2} u_t$, and $x_t^C = -\lambda u_t$. As the public can re-optimize every period current wages will

always equal current inflation leaving no flexibility to stabilize neither inflation nor output.³⁰

It is straightforward to see that stabilization flexibility - the ability to achieve better policies in the spirit of Bernanke (2003) - increases with wage rigidity and verify from (14) that

$$\forall \alpha > 0, \quad \frac{\partial |(\pi_t^C)^*|}{\partial r^p} < 0 \quad \text{and} \quad \frac{\partial |(x_t^C)^*|}{\partial r^p} < 0.^{31}$$

In S periods wage inflation is still at the level set at the nearest preceding Cournot period,

$$w_t^S = w_{t-h}^C = \frac{\pi_{t-h}^C}{r^p} \quad \text{where} \quad r_{\bar{\pi}}^s > h \geq 1. \quad \text{From} \quad \frac{\partial |(\pi_{t-h}^C)^*|}{\partial r^p} < 0 \quad \text{it follows that} \quad |(w_t^S)^*| \quad \text{and hence} \quad |(\pi_t^S)^*|$$

and $|(x_t^S)^*|$ are all decreasing in r^p concluding the proof of Proposition 2 (since these absolute values translate into expected variability). Intuitively, the fact that $(w_t^S)^*$ is *not* a function of current inflation, π_t^S , can be exploited by the policymaker³² implying that Stackelberg inflation and output are better stabilized (less volatile) than Cournot. The fact that the number of Stackelberg periods relative to Cournot periods is increasing in r^p reinforces the proposition.

In the light of these results let us examine players' choices of $r_{\bar{\pi}}^s$ and r^p under shocks. It is apparent that the public faces a trade-off. Flexibility of its instrument (low r^p) ensures better maximization of (2) but it must be purchased for a fee $c_F = \frac{c_f}{r^p}$. Clearly, for sufficiently *low* c_f the public will always choose to have fully flexible wages, $(r^p)^* = 1$. In contrast, for *sufficiently large* c_f (but not extremely large due to the assumed $c_{\bar{\pi}} > c_f$) some

³⁰ The intuition of this result parallels that of Cukierman (2001) and Gersbach (2003) who show that (under some settings) public's full information may prevent policymaker's stabilization.

³¹ As 'stabilization flexibility' refers to the *ability* rather than the *need* to stabilize let us explain the precise nature of our result. Proposition 2 shows that under rigid wages the policymaker's stabilization tradeoff is improved (the Taylor curve shifts inwards), i.e. she is able to choose from a *range* of output/inflation volatility combinations that are Pareto superior to the ones under flexible wages.

³² Note that this is similar to the New Keynesian framework of the Clarida, Gali and Gertler (1999) type in which the Phillips curve features $E_t \pi_{t+1}$, i.e. there is no *contemporaneous* effect limiting stabilization.

wage rigidity may be optimal. In particular, the *sufficient* condition for $(r^p)^*$ to still be an increasing function of $r_{\bar{\pi}}^g$ in the SR is $\frac{c_{\bar{\pi}}}{2} > c_f > \bar{c}_f = \frac{16}{27} \sigma_u^2$ (see the derivation in the Appendix). This means that if shocks are not too large and frequent relative to the flexibility cost then claim (iii) of Proposition 1 still obtains under shocks. Put differently, for a sufficiently large flexibility cost, $c_f > \bar{c}_f$, and sufficiently explicit inflation target the existence of supply shocks will not affect public's optimal choice of the length of the wage contract.³³

In terms of the policymaker, if she takes the 'anchoring' effect of its LR inflation commitment on wages into account not only does she commit sufficiently to ensure the Ramsey outcome in trends (i.e. the assumed $r_{\bar{\pi}}^g \geq 3\alpha r^p$), she commits as strongly as possible, $(r_{\bar{\pi}}^g)^* \rightarrow \infty$. In other words, the LR inflation target will be made extremely explicit (rigid). This implies that the remaining claims of Proposition 1 hold in the presence of shocks as well.

Let us now focus on the required changes in the interest rate instrument. It is straightforward to show that to achieve the improved stabilization in (14) a *less* aggressive interest rate response is necessary on average. In Stackelberg periods the equilibrium adjustment of the interest rate to *current* shocks is independent of r^p whereas in Cournot periods it is decreasing in wage rigidity. This can be shown by substituting (12)-(14) into the

IS curve to obtain $(i_t^c)^* = \left(\frac{\lambda}{\alpha\varphi} + \frac{1}{r^p} \right) (\pi_t^c)^* + \frac{g_t}{\varphi}$. Since $\frac{\partial |(\pi_t^c)^*|}{\partial r^p} < 0$, it follows that

$\frac{\partial |(i_t^c)^*|}{\partial r^p} < 0$. Combining the above claims proves, under $c_f > \bar{c}_f = \frac{16}{27} \sigma_u^2$, the main result of

the paper.

³³ If the variance of the supply shocks is excessively high relative to the flexibility cost the public will always choose to have fully flexible wages, $(r^p)^* = 1$. Then wage rigidity is independent of the explicitness of IT.

Proposition 3: *The policymaker's LR inflation commitment (explicit IT) increases stabilization flexibility and reduces the volatility of output, inflation and the interest rate.*

6 Discussion and Empirical Evidence

Intuitively, under an explicit (rigid) inflation target wage contracts will be longer. Since wage setters optimally spread supply shocks over the life of the contract there will be less volatility in wage inflation and hence less volatility in all key variables.³⁴ Taking the limiting case, under an irrevocable inflation target, $r_{\bar{\pi}}^g \rightarrow \infty$, the optimal r^p is large (but finite) and the public acts as if there exist no shocks, i.e. *looks-through* them even if a shock is observed when wages are being renegotiated, $u_t^C \neq 0$. Wages can then be said to be well anchored at the level of the inflation target, $w_t^C \cong \bar{w} = \bar{\pi}$.³⁵ The following quote by the central banker who 'taught' IT to the world, ex-governor of the Reserve Bank of New Zealand Donald Brash (2002), nicely summarizes our findings in several respects, stressing the desirability of (i) agents' looking through shocks (ii) anchorness of expectations, and the resulting (iii) improved stabilization and (iv) lower interest volatility: *To put it bluntly, if the Reserve Bank is to be able to 'look through' the impact of things like the increase in petrol and cigarette prices in implementing monetary policy, we New Zealanders also need to 'look through' the impact of those things on the CPI. To the extent that we don't, and instead seek compensation for the impact of those things on the CPI, the Bank will need to tighten monetary policy to a greater extent... In recent years, the Reserve Bank has been happy to report that inflationary*

³⁴ Note that similarly to the New Keynesian framework under SR discretion demand shocks are perfectly stabilized regardless of public's rigidity.

³⁵ The same can be said about inflation expectations as well. As we explained earlier while public's instrument is not directly interpretable as inflation expectations due to our simplifying informational assumptions, the insights about public's rigid wage setting apply to as well. In a richer setting a cost of updating expectations could be postulated and public's optimal updating frequency derived.

expectations are now well anchored at a low level. We have been able to say that, as a result, we expect that smaller adjustments in interest rates will be required...'

As the theoretic findings consistent with our results, namely Orphanides and Williams (2003) and Cubitt (1992), were discussed in the introduction, let us now survey the existing empirical evidence on these effects of IT. While the evidence is far from conclusive on the majority of issues (due to different techniques and specifications used), it seems to speak in favour of our results. In terms of the anchoring role of IT Levin, Natalucci and Piger (2004) find evidence that IT plays a significant role in anchoring long-term inflationary expectations and in reducing the persistence of inflation. Similarly, Kuttner and Posen (1999) and Gurkaynak, Sack and Swanson (2005) find that in IT countries compared to non-IT countries longer-run inflation expectations are less sensitive to economic developments. In contrast, Johnson (2002) and Ball and Sheridan (2003) find no evidence that IT reduces the variability of inflation expectations.³⁶

In terms of output variability, the findings are even more inconclusive on the basis of which McCallum (2003) argues: *'There is probably no way that this disagreement [on IT's flexibility] can be settled in the present state of economic knowledge'* - see e.g. Cecchetti and Ehrmann (1999), Eijffinger and Geraats (2002), and Demertzis and Hughes Hallett (2003). There seem to three recent exceptions; Corbo, Landerretche and Schmidt-Hebbel (2001) and Arestis, Caporale and Cipollini (2002) find IT to *improve* the variability tradeoff and Fatas, Mihov and Rose (2004) similarly find that 'having a quantitative de jure target for monetary authority tends to ... smooth business cycles; hitting the target de facto has further positive effects'. Finally, in terms of interest rate variability Siklos (2004) and Neumann and von

³⁶ See also Gertler (2003) for objections to the latter paper.

Hagen (2002) report evidence that IT countries have reduced the nominal interest rate and its volatility to a larger extent than non-IT countries. Further, Eijffinger and Geraats (2004) show that transparency reduces interest rates. There however exist opposing views, see Truman (2003).

It is important to note that we have assumed throughout the inflation target to be specified over the medium-long-term (LR). Only then the two policy instruments are mutually consistent, i.e. the commitment to the inflation target does not inhibit output stabilization. However, a targeting horizon shorter than the business cycle then there may lead to a conflict between the inflation objective and the dual mandate.³⁷

We point out again that our case $r_t^s = 1$ which we referred to as discretion is compatible with the standard pre-commitment solution popularized by Woodford (1999) and Clarida, Gali and Gertler (1999) and the implied ‘timeless perspective’ targeting rule. It is interesting to note that these two commitment concepts impact in the same direction – both anchor wages and expectations to change less than it would be the case under discretion. More research is needed to shed light on the real world relevance of these two channels and the magnitude of their welfare effects.

Finally, let us consider the two simplifications made to the New Keynesian framework of Clarida, Gali and Gertler (1999), namely serial correlation in supply shocks and households’ consumption smoothing. In terms of the former, the disturbance term is written as an AR(1) process $u_t = \rho u_{t-1} + \hat{u}_t$ with $\hat{u} \sim iid(0, \sigma_u^2)$. In the realistic case of $\rho < 1$ the process has a mean

³⁷ This is true of both inflation targeters from transition and developing countries whose inflation targets are specified over one year period and the inflation forecast targeting of the Bank of England type - see Svensson (1997a) - with its two year horizon. See e.g. Mishkin (2004) who argues that this short targeting horizon has not been binding only due to absence of supply shocks. The real world experience suggests that the inflation targeting regime may have to start off as rather strict (short-sighted) to gain credibility and can later be reformulated as a LR objective allowing more flexibility. This is especially true if IT is used as a disinflation device.

which ensures the independence of LR and SR in equation (6) and implies that an explicit trend-inflation target does not inhibit stabilization of shocks. Due to persistence in shocks the processes for inflation and the output gap will differ somewhat – the terms $E_t u_{t+i}$ and $E_t \pi_{t+i}$ will now be functions of past supply shocks. Nevertheless, their volatility will still be decreasing in r^p through the mechanism studied above so all previous conclusions hold.

In terms of consumption smoothing, this is commonly represented by an expected output term of the form $E_t x_{t+1}$ in the IS equation. It is apparent that the policy objectives are again best achieved if these expectations are anchored at the trend level. If it is not the case, after a cost push shock in t we will observe $E_t x_{t+1} < 0$ (which follows from the fact that $x_t < 0$ from equation (14)). This will tend to further decrease the current output gap, x_t , and therefore lead to Pareto inferior outcomes.

7 Summary and Conclusions

The paper provides a new tool to examine the impact of explicit inflation targets on the policymaker’s flexibility and the resulting stabilization outcomes. In contrast to the widespread belief, we find that a numerical target postulated as a long-term objective may, through its anchoring effect on public’s behaviour, increase stabilization flexibility and improve the variability tradeoff.

This is because under a credible long-term inflation target the public is likely to adjust wages and expectations less frequently in order to minimize the cost associated with their revision/adjustment. Well anchored behaviour of the public (to the target level) enables the policymaker to more effectively (and with smaller changes in the interest rate instrument) fine-tune the economy and reduce the volatility of both inflation and output. We show that while the empirical evidence is not conclusive, there exists fair support for all our results.

References

- ALESINA, A., and L. H. SUMMERS (1993): "Central Bank Independence and Macroeconomic Performance: Some Comparative Evidence," *Journal of Money, Credit, and Banking*, 25, 151-62.
- APEL, M., R. FRIBERG, and K. HALLSTEN (2005): "Microfoundations of Macroeconomic Price Adjustment: Survey Evidence from Swedish Firms," *Journal of Money, Credit, and Banking*, 37, 313-38.
- ARESTIS, P., G. M. CAPORALE, and A. CIPOLLINI (2002): "Does Inflation Targeting Affect the Trade-Off between Output Gap and Inflation Variability?," *Manchester School*, 70, 528-45.
- BACKUS, D., and J. DRIFFILL (1985): "Rational Expectations and Policy Credibility Following a Change in Regime," *Review of Economic Studies*, 52, 211-21.
- BALL, L. (1997): "Efficient Rules for Monetary Policy," National Bureau of Economic Research Inc NBER Working Papers: 5952.
- BALL, L., and N. SHERIDAN (2003): "Does Inflation Targeting Matter?," International Monetary Fund IMF Working Papers: 03/129.
- BARRO, R. J., and D. B. GORDON (1983a): "A Positive Theory of Monetary Policy in a Natural Rate Model," *Journal of Political Economy*, 91, 589-610.
- (1983b): "Rules, Discretion and Reputation in a Model of Monetary Policy," *Journal of Monetary Economics*, 12, 101-21.
- BERNANKE, B. S. (2003): "Perspective on Inflation Targeting," Remarks at the annual Washington Policy Conference of the National Association of Business Economists, Washington, D.C., March 25, 2003.
- BERNANKE, B. S., T. LAUBACH, F. S. MISHKIN, and A. POSEN (1999): *Inflation Targeting: Lessons from the International Experience*. Princeton: Princeton University Press.
- BERNANKE, B. S., and M. WOODFORD (2005): "The Inflation-Targeting Debate," *NBER Studies in Business Cycles*, vol. 32. Chicago and London: University of Chicago Press, ix, 458.
- BEWLEY, T. F. (2002): "Fairness, Reciprocity, and Wage Rigidity," Cowles Foundation Yale University Cowles Foundation Discussion Papers: 1383, Cowles Foundation Discussion Papers 1383, 2002, 36 pages.
- BHASKAR, V. (2002): "On Endogenously Staggered Prices," *Review of Economic Studies*, 69, 97-116.
- BLEJER, M. I., A. IZE, A. M. LEONE, and S. WERLANG (2000): *Inflation Targeting in Practice: Strategic and Operational Issues and Application to Emerging Market Countries*. International Monetary Fund.
- BLINDER, A. S. (1997): "Is There a Core of Practical Macroeconomics That We Should All Believe?," *American Economic Review*, 87, 240-43.
- BRASH, D. T. (2002): "Inflation Targeting 14 Years On," a speech delivered at the American Economic Association conference, Atlanta, January 5.
- BRIAULT, C., A. HALDANE, and M. KING (1997): "Independence and Accountability," in *Towards More Effective Monetary Policy*, ed. by I. e. Kuroda. London: Macmillan Press in association with Bank of Japan, 299-326.
- CALVO, G. A. (1983): "Staggered Prices in a Utility-Maximizing Framework," *Journal of Monetary Economics*, 12, 383-98.
- CANZONERI, M. B. (1985): "Monetary Policy Games and the Role of Private Information," *American Economic Review*, 75, 1056-70.

- CECCHETTI, S. G., and M. EHRMANN (1999): "Does Inflation Targeting Increase Output Volatility? An International Comparison of Policymakers' Preferences and Outcomes," National Bureau of Economic Research Inc NBER Working Papers: 7426.
- CHO, I., and A. MATSUI (2005): "Time Consistency in Alternating Move Policy Games," Japanese Economic Review.
- CHORTAREAS, G., D. STASAVAGE, and G. STERNE (2002): "Does It Pay to Be Transparent? International Evidence from Central Bank Forecasts," Federal Reserve Bank of St. Louis Review, 84, 99-117.
- CLARIDA, R., J. GALI, and M. GERTLER (1999): "The Science of Monetary Policy: A New Keynesian Perspective," Journal of Economic Literature, 37, 1661-707.
- CORBO, V., O. LANDERRETICHE, and K. SCHMIDT-HEBBEL (2001): "Assessing Inflation Targeting after a Decade of World Experience," International Journal of Finance and Economics, 6, 343-68.
- CUBITT, R. P. (1992): "Monetary Policy Games and Private Sector Precommitment," Oxford Economic Papers, 44, 513-30.
- CUKIERMAN, A. (1999): "The Inflation Bias Result Revisited," Tel Aviv Tel Aviv, 1999, 19 pages.
- (2001): "Accountability, Credibility, Transparency and Stabilization Policy in the Eurosystem," in The Impact of Emu on Europe and the Developing Countries, ed. by C. Wyplosz: Oxford University Press, 40-75.
- CUKIERMAN, A., and S. GERLACH (2003): "The Inflation Bias Revisited: Theory and Some International Evidence," Manchester School, 71, 541-65.
- CUKIERMAN, A., and F. LIPPI (1999): "Central Bank Independence, Centralization of Wage Bargaining, Inflation and Unemployment: Theory and Some Evidence," European Economic Review, 43, 1395-434.
- CUKIERMAN, A., and A. H. MELTZER (1986): "A Theory of Ambiguity, Credibility, and Inflation under Discretion and Asymmetric Information," Econometrica, 54, 1099-128.
- CUKIERMAN, A., S. B. WEBB, and B. NEYAPTI (1992): "Measuring the Independence of Central Banks and Its Effect on Policy Outcomes," World Bank Economic Review, 6, 353-98.
- D'ARTIGUES, A., and T. VIGNOLO (2005): "An Evolutionary Theory of the Convergence Towards Low Inflation Rates," Journal of Evolutionary Economics, 15, 51-64.
- DE HAAN, J., F. AMTENBRINK, and S. C. W. ELJFFINGER (1999): "Accountability of Central Banks: Aspects and Quantification," Banca Nazionale del Lavoro Quarterly Review, 52, 169-93.
- DE LONG, J. B. (1998): "Fiscal Policy in the Shadow of the Great Depression," in The Defining Moment: The Great Depression and the American Economy in the Twentieth Century, ed. by M. D. Bordo, C. Goldin, and E. N. White. NBER Project Report series. Chicago and London: University of Chicago Press, 67-85.
- DEBELLE, G. (1997): "Inflation Targeting in Practice," International Monetary Fund IMF Working Papers: 97/35.
- DEMERTZIS, M., and A. HUGHES HALLETT (2003): "Three Models of Imperfect Transparency in Monetary Policy," C.E.P.R. Discussion Papers CEPR Discussion Papers: 4117.
- DENNIS, R., and U. SODERSTROM (2002): "How Important Is Precommitment for Monetary Policy?," Federal Reserve Bank of San Francisco Working Papers in Applied Economic Theory: 2002-10.
- ELJFFINGER, S., and E. SCHALING (1993): "Central Bank Independence in Twelve Industrial Countries," Banca Nazionale del Lavoro Quarterly Review, 0, 49-89.

- EIJFFINGER, S. C. W., and P. M. GERAATS (2002): "How Transparent Are Central Banks?," C.E.P.R. Discussion Papers CEPR Discussion Papers: 3188.
- (2004): "Does Central Bank Transparency Reduce Interest Rates?," available at: http://www.econ.cam.ac.uk/cgi-bin/research.pl?terms=geraats&conf_file=paper.conf&series=camdae&criteria=Search&case=Insensitive.
- EIJFFINGER, S. C. W., M. HOEBERICHTS, and E. SCHALING (1998): "A Theory of Central Bank Accountability," Tilburg University Center for Economic Research Discussion Paper: 103.
- FATAS, A., I. MIHOV, and A. K. ROSE (2004): "Quantitative Goals for Monetary Policy," National Bureau of Economic Research Inc NBER Working Papers: 10846.
- FAUST, J., and L. E. O. SVENSSON (2001): "Transparency and Credibility: Monetary Policy with Unobservable Goals," *International Economic Review*, 42, 369-97.
- (2002): "The Equilibrium Degree of Transparency and Control in Monetary Policy," *Journal of Money, Credit, and Banking*, 34, 520-39.
- FISCHER, S. (1977): "Long-Term Contracts, Rational Expectations, and the Optimal Money Supply Rule," *Journal of Political Economy*, 85, 191-205.
- FRIEDMAN, B. M. (2004): "Why the Federal Reserve Should Not Adopt Inflation Targeting," *International Finance*, 7, 129-36.
- FRY, M., D. JULIUS, L. MAHADEVA, S. ROGER, and G. STERNE (2000): "Key Issues in the Choice of a Monetary Policy Framework," in *Monetary Frameworks in a Global Context*, ed. by L. Mahadeva, and G. Sterne. London: Routledge.
- FUHRER, J. C. (1997): "Inflation/Output Variance Trade-Offs and Optimal Monetary Policy," *Journal of Money, Credit, and Banking*, 29, 214-34.
- GARFINKEL, M. R., and S. OH (1995): "When and How Much to Talk: Credibility and Flexibility in Monetary Policy with Private Information," *Journal of Monetary Economics*, 35, 341-57.
- GERSBACH, H. (2003): "On the Negative Social Value of Central Banks' Knowledge Transparency," *Economics of Governance*, 4, 91-102.
- GOODFRIEND, M. (2003): "Inflation Targeting in the United States?," National Bureau of Economic Research Inc NBER Working Papers: 9981.
- GRILLI, V., D. MASCIANDARO, and G. TABELLINI (1991): "Political and Monetary Institutions and Public Financial Policies in the Industrial Countries," *Economic Policy: A European Forum*, 0, 341-92.
- GURKAYNAK, R. S., B. SACK, and E. SWANSON (2005): "The Sensitivity of Long-Term Interest Rates to Economic News: Evidence and Implications for Macroeconomic Models," *American Economic Review*, 95, 425-36.
- HUCK, S., W. MULLER, and H.-T. NORMANN (2002): "To Commit or Not to Commit: Endogenous Timing in Experimental Duopoly Markets," *Games and Economic Behavior*, 38, 240-64.
- HUGHES HALLETT, A., and J. LIBICH (2004): "Central Bank Independence, Accountability, and Transparency: Democratic Complements or Strategic Substitutes?," Centre for Economic Policy Research, London.
- HUGHES HALLETT, A., and N. VIEGI (2003): "Imperfect Transparency and the Strategic Use of Information: An Ever Present Temptation for Central Bankers?," *Manchester School*, 71, 498-520.
- JENSEN, H. (2002): "Optimal Degrees of Transparency in Monetary Policymaking," *Scandinavian Journal of Economics*, 104, 399-422.

- JOHNSON, D. R. (2002): "The Effect of Inflation Targeting on the Behavior of Expected Inflation: Evidence from an 11 Country Panel," *Journal of Monetary Economics*, 49, 1521-38.
- KANDORI, M., G. J. MAILATH, and R. ROB (1993): "Learning, Mutation, and Long Run Equilibria in Games," *Econometrica*, 61, 29-56.
- KING, M. (1998): "The Inflation Target Five Years On," *London School Of Economics*, 99.
- KING, R. G., and A. KURMANN (2002): "New Keynesian Pricing Models," available at <http://www.er.uqam.ca/nobel/r10735/9011/pricingnew.pdf>.
- KOHN, D. L. (2003): "Remarks at the 28th Annual Policy Conference: Inflation Targeting: Prospects and Problems," *Federal Reserve Bank of St. Louis*, St. Louis, Missouri.
- KUTTNER, K. N. (2004): "A Snapshot of Inflation Targeting in Its Adolescence," in *The Future of Inflation Targeting*, ed. by C. Kent, and S. Guttman. Sydney: The Reserve Bank of Australia, pp.6-42.
- KUTTNER, K. N., and A. S. POSEN (1999): "Does Talk Matter after All? Inflation Targeting and Central Bank Behavior," *Staff Reports 88*, Federal Reserve Bank of New York.
- KYDLAND, F. E., and E. C. PRESCOTT (1977): "Rules Rather Than Discretion: The Inconsistency of Optimal Plans," *Journal of Political Economy*, 85, 473-91.
- LACKER, J. M. (2005): "Inflation Targeting and the Conduct of Monetary Policy," a speech delivered by President of the Federal Reserve Bank of Richmond, University of Richmond, March 1.
- LAGUNOFF, R., and A. MATSUI (1997): "Asynchronous Choice in Repeated Coordination Games," *Econometrica*, 65, 1467-77.
- LEVIN, A. T., F. M. NATALUCCI, and J. M. PIGER (2004): "The Macroeconomic Effects of Inflation Targeting," *Federal Reserve Bank of St. Louis Review*, 86, 51-80.
- LIBICH, J. (2004): "Incorporating Rigidity in Games: A Theory of Convergence to Low Inflation," mimeo, University of New South Wales.
- (2005): "A Generalization of the Commitment Concept as an Equilibrium Refinement," mimeo, University of New South Wales, (in progress).
- MANKIW, N. G., and R. REIS (2002): "Sticky Information Versus Sticky Prices: A Proposal to Replace the New Keynesian Phillips Curve," *Quarterly Journal of Economics*, 117, 1295-328.
- MASKIN, E., and J. TIROLE (1988): "A Theory of Dynamic Oligopoly, I: Overview and Quantity Competition with Large Fixed Costs," *Econometrica*, 56, 549-69.
- MCCALLUM, B., and E. NELSON (2004a): "Targeting Vs. Instrument Rules for Monetary Policy."
- (2004b): "Timeless Perspective Vs. Discretionary Monetary Policy in Forward-Looking Models," 43-56.
- MCCALLUM, B. T. (1997): "Crucial Issues Concerning Central Bank Independence," *Journal of Monetary Economics*, 39, 99-112.
- (2003): "Inflation Targeting for the United States," *Shadow Open Market Committee*, available at <http://www.somc.rochester.edu/May03/McCallum.pdf>.
- MISHKIN, F. S. (2004): "Why the Federal Reserve Should Adopt Inflation Targeting," *International Finance*, 7, 117-27.
- MISHKIN, F. S., and K. SCHMIDT-HEBBEL (2001): "One Decade of Inflation Targeting in the World: What Do We Know and What Do We Need to Know?," *National Bureau of Economic Research Inc NBER Working Papers*: 8397.
- NELSON, E. (2005): "Monetary Policy Neglect and the Great Inflation in Canada, Australia, and New Zealand," *International Journal of Central Banking*, May 2005.

- NEUMANN, M. J. M., and J. VON HAGEN (2002): "Does Inflation Targeting Matter?," *Federal Reserve Bank of St. Louis Review*, 84, 127-48.
- ORPHANIDES, A. (2003): "The Quest for Prosperity without Inflation," *Journal of Monetary Economics*, 50, 633-63.
- ORPHANIDES, A., and J. C. WILLIAMS (2003): "Imperfect Knowledge, Inflation Expectations, and Monetary Policy," *National Bureau of Economic Research Inc NBER Working Papers*: 9884.
- ROGOFF, K. (1985): "The Optimal Degree of Commitment to an Intermediate Monetary Target," *Quarterly Journal of Economics*, 100, 1169-89.
- ROMER, C. D., and D. H. ROMER (1997): "Reducing Inflation: Motivation and Strategy," *NBER Studies in Business Cycles*, vol. 30. Chicago and London: University of Chicago Press, ix, 421.
- RUDEBUSCH, G. D., and C. E. WALSH (1998): "U.S. Inflation Targeting: Pro and Con," *FRBSF Economic Letter*.
- RUGE-MURCIA, F. J. (2003): "Inflation Targeting under Asymmetric Preferences," *Journal of Money, Credit, and Banking*, 35, 763-85.
- (2004): "The Inflation Bias When the Central Bank Targets the Natural Rate of Unemployment," *European Economic Review*, 48, 91-107.
- SCHALING, E., and C. NOLAN (1998): "Monetary Policy Uncertainty and Inflation: The Role of Central Bank Accountability," *De Economist*, 146, 585-602.
- SIKLOS, P. L. (2004): "Central Bank Behavior, the Institutional Framework, and Policy Regimes: Inflation Versus Noninflation Targeting Countries," *Contemporary Economic Policy*, 22, 331-43.
- SOUSA, P. (2002): "Central Bank Independence and Democratic Accountability," mimeo, *Portucalense University*.
- SVENSSON, L. E. O. (1997a): "Inflation Forecast Targeting: Implementing and Monitoring Inflation Targets," *European Economic Review*, 41, 1111-46.
- (1997b): "Optimal Inflation Targets, "Conservative" Central Banks, and Linear Inflation Contracts," *American Economic Review*, 87, 98-114.
- (1999): "Inflation Targeting as a Monetary Policy Rule," *Journal of Monetary Economics*, 43, 607-54.
- TAYLOR, J. B. (1979): "Staggered Wage Setting in a Macro Model," *American Economic Review*, 69, 108-13.
- (1980): "Aggregate Dynamics and Staggered Contracts," *Journal of Political Economy*, 88, 1-23.
- (1997): "America's Peacetime Inflation: The 1970s: Comment," in *Reducing Inflation: Motivation and Strategy*, ed. by C. D. Romer, and D. H. Romer. *NBER Studies in Business Cycles*, vol. 30. Chicago and London: University of Chicago Press, 276-80.
- TRUMAN, B. (2003): "Inflation Targeting in the World Economy," *Washington, D.C.: Institute for International Economics*, xvi, 261.
- WOODFORD, M. (1999): "Optimal Monetary Policy Inertia," *Manchester School*, 67, 1-35.
- (2003): "Optimal Interest-Rate Smoothing," *Review of Economic Studies*, 70, 861-86.

Appendix A

Derivation of \bar{c}_f

We aim to derive a sufficient condition, a level of \bar{c}_f above which public's expected utility conditional on the information available in period $t=0$ (in which the public makes its r^p choice) is *monotonously* increasing in r^p . Then $(r^p)^*$ will be an increasing function of LR commitment, namely $(r^p)^* = \frac{r^g}{3\alpha}$ as established in Proposition 1.

Public's one-period utility in period t equals $U_t^{p,z} = -(\pi_t^z - w_t^z)^2 - c_F$, where $z = \{C, S\}$, i.e. depends on whether wages can be renegotiated in that period. The *average* expected per-period utility expected in $t=0$ is then the following weighted average

$$E_0 \bar{U}_t^p = \frac{1}{r^p} E_0 \bar{U}^{p,C} + \left(1 - \frac{1}{r^p}\right) E_0 \bar{U}^{p,S} - \frac{c_f}{r^p} \quad (15)$$

The expected utility in Cournot and Stackelberg periods is weighted by their relative incidence. To find a minimum let us substitute in (15) the above derived C values π_t^C, w_t^C ,

together with the S values $\pi_t^S = \frac{\alpha}{\alpha + \lambda^2} u_t + \frac{\alpha^2}{[\lambda^2 r^p + \alpha(r^p - 1)](\alpha + \lambda^2)} u_{t-h}$ and

$w_t^S = \frac{\alpha}{\lambda^2 r^p + \alpha(r^p - 1)} u_{t-h}$, where $r^g > h \geq 1$. Differentiating with respect to r^p , setting equal

to zero, using $u \sim iid(0, \sigma_u^2)$, $E_0 u_{t \geq 1} = 0$, $E_0 u_{t \geq 1}^2 = \sigma_u^2$ and rearranging yields

$$\bar{c}_f = \frac{2\lambda^2 \alpha^2 (r^p)^2 (r^p - 1)}{[\lambda^2 r^p + \alpha(r^p - 1)]^3} \sigma_u^2 \quad (16)$$

This \bar{c}_f is, however, a non-monotonous function of r^p . To derive a sufficient condition we find its maximum by differentiating it with respect to r^p and setting equal to zero which

yields $r^p = \frac{2\alpha}{2\alpha - \lambda^2}$. Since r^p is an interger the maximum \bar{c}_f is implied to be at $r^p = 2$ (this is due to the non-linearities in (15)).

We then substitute $r^p = 2$ into (16) to obtain a sufficient condition under which $E_0U_t^p$ is *monotonously* increasing in r^p , that is $c_f > \bar{c}_f = \frac{8\lambda^2\alpha^2}{(2\lambda^2 + \alpha)^3}\sigma_u^2$. To evaluate the RHS let

$$\Lambda = \lambda^2 \quad \text{and} \quad f(\Lambda, \alpha) = \frac{8\Lambda\alpha^2}{(2\Lambda + \alpha)^3}. \quad \text{Then} \quad \frac{\partial f}{\partial \Lambda} = \frac{8\alpha^3 - 32\alpha^2\Lambda}{(2\Lambda + \alpha)^4}$$

and this has a zero only at $\Lambda = \alpha/4$. To check whether it is a maximum and whether it is global we calculate

$$\frac{\partial^2 f}{\partial \Lambda^2} = \frac{192\alpha^2\Lambda - 96\alpha^3}{(2\Lambda + \alpha)^5} \quad \text{which at } \Lambda = \alpha/4 \text{ yields } -\frac{521}{243\alpha^2} < 0. \quad \text{This implies that for any value}$$

of α the function f takes its maximal value at $\Lambda = \alpha/4$. Concentrating then on $f(\frac{\alpha}{4}, \alpha)$

the function becomes $f(\frac{\alpha}{4}, \alpha) = \frac{16}{27}, \forall \alpha$ implying that for all α , Λ , and λ we have

$$c_f > \bar{c}_f = \frac{16}{27}\sigma_u^2 \quad \text{which is the sufficient condition in the text.}$$

Appendix B

Central Bank Accountability Index (Sousa, 2002)

Criteria and methodology adopted from De Haan et al. (1998). We only use the ‘final responsibility’ component that best proxies policymaker’s commitment.

FINAL RESPONSIBILITY	1) Is the central bank subject of monitoring by Parliament?	1.00
	2) Has the government (or Parliament) the right to give instruction?	1.00
	3) Is there some kind of review in the procedure to apply the override mechanism?	1.00
	4) Has central bank possibility for an appeal in case of an instruction?	1.00
	5) Can the central bank law be changed by a simple majority in Parliament?	1.00
	6) Is past performance a ground for dismissal of a central bank governor?	1.00

Central Bank Independence Index (Sousa, 2002)

	Criteria	Points
PERSONAL INDEPENDENCE	1. Appointment of the central bank board members	
	a) All the appointments to the central bank board are made independently of the government.	1.00
	b) More than half of the appointments to the central board are made independently of the government.	0.66
	c) Less than half of the appointments to the central board are made independently of the government.	0.33
	d) Government has influence in all the appointments to the central bank board.	0.00
	2. Mandate duration of more than half of the central bank board members.	
	a) Equal or more than eight years	1.00
	b) Between six and eight years.	0.75
	c) Five years.	0.50
	d) Four years.	0.25
	e) Less than four years.	0.00
	3. Government (or other fiscal branches representatives) participation at central bank meetings, where monetary decisions are taken.	
	a) No government representation at central bank meetings.	1.00
b) Government is represented at central bank meetings, but without right to vote.	0.50	
c) Government is represented at central bank meetings, with right to vote.	0.00	
POLITICAL INDEPENDENCE	4. Ultimate responsibility and authority on monetary policy decisions.	
	a) Central bank has the ultimate (final) responsibility on monetary policy decisions.	1.00
	b) Central bank has not the ultimate responsibility on monetary policy decisions.	0.00
	5. Price stability	
	a) It is the sole objective.	1.00
	b) It is one of two objectives, but it is given preference to price stability.	0.66
	c) It is one among various others objectives.	0.33
	d) Law does not establish anything about policy objectives.	0.00
	6. Banking supervision	
	a) Not considered in the objectives or functions of the central bank.	1.00
	b) It is one of the central bank functions or objectives, where we find also price stability as a policy objective.	0.50
	c) It dominates other central bank functions or objectives.	0.00
	7. Monetary policy instruments	
a) Central bank enjoys autonomy in monetary policy instruments selection.	1.00	
b) Central bank is not autonomous in the selection of monetary policy instruments.	0.00	
ECONOMIC AND FINANCIAL INDEPENDENCE	8. Government financing	
	a) Central Bank cannot directly finance the government.	1.00
	b) Law allows that central bank provide credit facilities to government and other financing help.	0.00
	9. Ownership of the central bank's (equity) capital	
	a) Government does not own any central bank's capital.	1.00
	b) Government owns less than half of the central bank's capital.	0.66
c) Government owns more than half of the central bank's capital.	0.33	
d) Government owns all the central bank's capital.	0.00	

Evaluation Table

Index	Independence Sousa (2002)*				Accountability Sousa (2002)*	
	Personal	Political	Economic / Financial	Total#	Final Responsibility	

1	Argentina	1.25	2.83	1.00	5.08	2
2	Australia	0.50	2.16	0.00	2.66	5
3	Austria	1.66	3.16	1.00	5.82	1
4	Belgium	1.75	1.50	0.00	3.25	4
5	Canada	0.50	1.83	0.00	2.33	4
6	Chile	2.00	1.83	1.00	4.83	3
7	Czech Republic	1.58	3.16	1.00	5.74	2
8	Denmark	2.16	2.83	0.00	4.99	2
9	EMU - ECB	2.50	3.66	1.00	7.16	1
10	England	1.00	2.66	0.00	3.66	4
11	Finland	2.50	3.66	1.00	7.16	2
12	France	1.50	3.16	1.00	5.66	2
13	Germany	1.50	3.16	1.00	5.66	2
14	Greece	1.91	3.16	1.00	6.07	1
15	Hungary	1.91	3.66	1.00	6.57	2
16	Iceland	1.75	3.33	0.00	5.08	4
17	Ireland	1.00	3.16	1.00	5.16	2
18	Italy	2.16	3.16	1.00	6.32	1
19	Japan	0.75	3.66	0.00	4.41	3
20	Korea	0.75	2.16	0.00	2.91	4
21	Luxemburg	1.25	3.16	1.00	5.41	2
22	Mexico	1.83	2.33	0.00	4.16	2
23	Netherlands	2.41	3.16	0.00	5.57	2
24	New Zealand	1.83	2.16	1.00	4.99	4
25	Norway	1.58	1.83	0.00	3.41	5
26	Poland	1.25	2.16	0.00	3.41	3
27	Portugal	1.50	3.16	1.00	5.66	1
28	Slovakia	1.00	3.50	1.00	5.50	1
29	Spain	0.75	3.16	1.00	4.91	2
30	Sweden	2.75	3.16	1.00	6.91	1
31	Switzerland	2.08	3.33	1.00	6.41	2
32	Turkey	1.66	2.83	0.00	4.49	3
33	USA	2.00	1.83	0.00	3.83	2

**Assessment is based on situation in January 2002. # Excludes aspect 9 due to missing observations.*