

CAMA

Centre for Applied Macroeconomic Analysis

Financial Contagion and Asset Pricing

CAMA Working Paper 61/2013 September 2013

Renée Fry-McKibbin

Crawford School of Public Policy, ANU

Centre for Applied Macroeconomic Analysis (CAMA), ANU

Vance Martin

Department of Economics, University of Melbourne

Centre for Applied Macroeconomic Analysis (CAMA), ANU

Chrismin Tang

School of Economics, La Trobe University

Centre for Applied Macroeconomic Analysis (CAMA), ANU

Abstract

Asset market interconnectedness can give rise to significant contagion risks during periods of financial crises that extend beyond the risks associated with changes in volatilities and correlation. These channels include the transmission of shocks operating through changes in the higher order comoments of asset returns, including changes in coskewness arising from changes in the interaction between volatility and average returns across asset markets. These additional contagion channels have nontrivial implications for the pricing of options through changes in the payoff probability structure and more generally, in the management of financial risks. The effects of incorrectly pricing risk has proved to be significant during many financial crises, including the subprime crisis from mid 2007 to mid 2008, the Great Recession beginning 2008 and the European debt crisis from 2010. Using an exchange options model, the effects of changes in the comoments of asset returns across asset markets are investigated with special emphasis given to understanding the effects on hedging risk during financial crises. The results reveal that by not correctly pricing the risks arising from higher order moments during financial crises, there is significant mispricing of options, while hedged portfolios during noncrisis periods become exposed to price movements in times of crises.

Keywords

Financial crises, Contagion, Exchange Options, Delta Hedging

JEL Classification

C51, G15

Address for correspondence:

(E) cama.admin@anu.edu.au

[The Centre for Applied Macroeconomic Analysis](#) in the Crawford School of Public Policy has been established to build strong links between professional macroeconomists. It provides a forum for quality macroeconomic research and discussion of policy issues between academia, government and the private sector.

The Crawford School of Public Policy is the Australian National University's public policy school, serving and influencing Australia, Asia and the Pacific through advanced policy research, graduate and executive education, and policy impact.

Financial Contagion and Asset Pricing

Renée Fry-McKibbin[#], Vance Martin⁺, and Chrismin Tang^{*}

[#]CAMA, Crawford School of Public Policy, Australian National University

⁺Department of Economics, University of Melbourne

^{*}School of Economics, La Trobe University

August 2013

Abstract

Asset market interconnectedness can give rise to significant contagion risks during periods of financial crises that extend beyond the risks associated with changes in volatilities and correlation. These channels include the transmission of shocks operating through changes in the higher order comoments of asset returns, including changes in coskewness arising from changes in the interaction between volatility and average returns across asset markets. These additional contagion channels have nontrivial implications for the pricing of options through changes in the payoff probability structure and more generally, in the management of financial risks. The effects of incorrectly pricing risk has proved to be significant during many financial crises, including the subprime crisis from mid 2007 to mid 2008, the Great Recession beginning 2008 and the European debt crisis from 2010. Using an exchange options model, the effects of changes in the comoments of asset returns across asset markets are investigated with special emphasis given to understanding the effects on hedging risk during financial crises. The results reveal that by not correctly pricing the risks arising from higher order moments during financial crises, there is significant mispricing of options, while hedged portfolios during noncrisis periods become exposed to price movements in times of crises.

Keywords: Financial crises, Contagion, Exchange Options, Delta Hedging

JEL Classification: C51, G15

*Author contact details are: Fry-McKibbin: renee.mckibbin@anu.edu.au; Martin: vance@unimelb.edu.au; Tang: chrismin.tang@latrobe.edu.au. The authors gratefully acknowledge Australian Research Council Grant DP0985783.

1 Introduction

The subprime financial crisis of 2007-2008, immediately followed by the Great Recession in mid 2008, and more recently the European debt crisis beginning 2010, reveal significant risks that arise from the interconnectedness of asset markets in the global financial landscape. The magnitude of shock transmissions from one market to others often far exceed expectations based on normal market linkages and dependence structures between assets (Dungey, Fry, González-Hermosillo and Martin (2010)). Not only do the codependence structures across financial markets change dramatically during periods of financial turbulence, these changes often extend beyond the usual changes in market correlation, and include additional crisis transmission channels operating through higher order comoments of asset returns (Fry, Martin and Tang (2010)).

The effect of changes in the comoments of asset returns on recent financial crises are highlighted in Tables 1 and 2. Table 1 provides the descriptive statistics on the first three moments of equity returns for five European countries and the US over four periods: a noncrisis period (January 3, 2006 to July 25, 2007), and three crisis periods consisting of the subprime crisis (July 26, 2007 to September 14, 2008), the Great Recession (September 15, 2008 to December 31, 2012) and the European debt crisis (January 1, 2010 to August 30, 2012) compared to the noncrisis period. All six countries are characterized by falls in average returns and increases in volatility during each crisis. Skewness also increases during the crisis periods, changing from negative skewness in the noncrisis period for equity returns of all six countries to either positive skewness or smaller negative skewness. Table 2 shows that similar results occur for coskewness between pairs of equity returns of countries, with coskewness changing from being negative in the noncrisis period to being either positive or a smaller negative coskewness in the crisis periods. The only exception is in Table 2 where coskewness between the US and Greece (last block of the table) becomes more negative during the Great Recession, changing from -0.181 to -0.238 .

Table 1:
Descriptive statistics on daily equity returns of selected countries for noncrisis and crisis periods: noncrisis (Jan. 3, 2006-Jul. 25, 2007); subprime crisis (Jul. 26, 2007-Sep. 14, 2008); Great Recession (Sep. 15, 2008-Dec. 31, 2012); European debt crisis (Jan. 1, 2010-Aug. 30, 2012).

		Noncrisis	Subprime	Great Recession	European Debt
France	Mean	0.087	-0.089	-0.025	-0.042
	Std dev.	1.010	1.593	2.887	2.017
	Skewness	-0.312	-0.200	0.177	0.058
Germany	Mean	0.131	-0.086	-0.019	0.034
	Std dev.	1.203	1.808	2.934	1.938
	Skewness	-0.610	-0.120	0.027	-0.201
Greece	Mean	0.117	-0.153	-0.099	-0.200
	Std dev.	1.196	1.707	2.896	2.626
	Skewness	-0.479	0.049	-0.202	0.388
Italy	Mean	0.066	-0.109	-0.055	-0.085
	Std dev.	0.943	1.428	2.980	2.314
	Skewness	-0.345	-0.191	0.092	-0.035
Spain	Mean	0.117	-0.079	0.017	-0.093
	Std dev.	0.968	1.639	2.759	2.272
	Skewness	-0.312	-0.264	0.026	0.279
US	Mean	0.062	-0.063	-0.027	0.032
	Std dev.	0.629	1.235	2.246	1.070
	Skewness	-0.545	-0.040	0.111	-0.410

Table 2:

Coskewness statistics of daily equity returns for noncrisis and crisis periods: noncrisis (Jan. 3, 2006-Jul. 25, 2007); subprime crisis (Jul. 26, 2007-Sep. 14, 2008); Great Recession (Sep. 15, 2008-Dec. 31, 2012); European debt crisis (Jan. 1, 2010-Aug. 30, 2012). Coskewness is calculated using $r_{1,t}r_{2,t}^2$. The first row of each block of the table corresponds to asset 1 and the following rows correspond to asset 2.

	Noncrisis	Subprime	Great Recession	European Debt
France ($i = 1$)				
Germany	-0.445	-0.086	0.046	-0.109
Greece	-0.203	-0.008	-0.016	0.120
Italy	-0.320	-0.178	0.127	0.007
Spain	-0.303	-0.243	0.110	0.203
US	-0.255	-0.119	-0.140	-0.208
Germany ($i = 1$)				
France	-0.355	-0.118	0.094	-0.027
Greece	-0.366	-0.065	-0.067	0.070
Italy	-0.376	-0.136	0.063	-0.044
Spain	-0.381	-0.178	0.049	0.122
US	-0.328	-0.116	-0.159	-0.265
Greece ($i = 1$)				
France	-0.168	-0.120	0.040	0.035
Germany	-0.423	-0.130	0.006	-0.076
Italy	-0.203	-0.198	0.066	0.042
Spain	-0.243	-0.139	-0.012	0.194
US	-0.296	-0.049	-0.217	-0.127
Italy ($i = 1$)				
France	-0.313	-0.197	0.152	0.037
Germany	-0.472	-0.098	0.045	-0.089
Greece	-0.261	-0.087	-0.005	0.136
Spain	-0.299	-0.216	0.111	0.176
US	-0.313	-0.083	-0.173	-0.177
Spain ($i = 1$)				
France	-0.303	-0.218	0.157	0.132
Germany	-0.467	-0.106	0.047	-0.015
Greece	-0.274	0.013	-0.064	0.207
Italy	-0.310	-0.173	0.126	0.073
US	-0.299	-0.058	-0.183	-0.117
US ($i = 1$)				
France	-0.200	0.089	0.001	-0.030
Germany	-0.216	-0.068	-0.062	-0.146
Greece	-0.181	0.237	-0.238	0.095
Italy	-0.233	0.154	0.031	-0.052
Spain	-0.243	0.089	-0.127	0.079

As the statistics in Tables 1 and 2 allude, asset mispricing can be particularly significant during periods of financial crisis and contagion and this has important implications for market participants engaged in the hedging of financial risks and for financial regulators seeking to manage risks across the financial institutions. This is particularly the case for exchange option contracts written on two or more assets where changes in the dependence structure of the underlying assets have a direct impact on the price of the option. Significant risk exposures to changes in higher order moments remain if hedging strategies are formulated using the standard Black-Scholes model that invokes multivariate normality.

To investigate the effects of contagion during financial crises on alternative hedging strategies, an exchange options model is developed following Fry, Martin and Tang (2010) which extends the usual Black-Scholes assumption of lognormal prices of the underlying assets that an option is written on, to a more general distribution that allows for the effects of higher order moments as well as comoments arising from coskewness (see also Lim, Lye, Martin and Martin (1998), Martin, Forbes and Martin (2003) and Lim, Martin and Martin (2006) in the case of non-exotic options). Special attention is given to identifying the size of mispricing from higher order comoments of asset returns during the crisis periods and how it impacts upon hedging strategies. The key results of the analysis reveal significant mispricing of options during financial crises from not pricing the risks associated with higher order moments. The analysis also shows that portfolios that are hedged against price movements during noncrisis periods become exposed to unfavorable price movements during periods of crises.

The adoption of a generalized normal distribution to capture higher order codependence in asset returns represents a natural choice as Fry, Martin and Tang (2010) show that Lagrange multiplier tests of contagion can be derived which relate to existing tests of comoments such as coskewness. An alternative approach to capture higher order dependence is based on using copulas (Patton (2006), Rodriguez (2007), Harvey (2010)

and Busetti and Harvey (2011)). This approach is also adopted by Martin and Wang (2013) who propose a nonparametric test of contagion. Earlier approaches, especially in the context of modelling options in the presence of nonnormal asset returns, consist of the lognormal mixture model of Melick and Thomas (1997); the Edgeworth expansion of Jarrow and Rudd (1982) and Corrado and Su (1997); the Hermite polynomial approximation of Ane (1999); the nonparametric density estimator of Aït-Sahalia, Wang and Yared (2001); and the neural network approach of Garcia and Gencay (2000). Moreover, the importance of transmission channels of contagion operating in higher order moments are investigated by Favero and Giavazzi (2002) and Pesaran and Pick (2007) who test for contagion in the outliers of asset returns; Bae, Karolyi and Stulz (2003) who propose a co-exceedance test based on a multinomial logit model; whereas Aït-Sahalia, Cacho-Diaz and Laeven (2010) allow for mutual jumps using a Hawkes process.

The rest of the paper proceeds as follows. The theoretical model is developed in Section 2 based on option contracts where one asset is exchanged for another. An important feature of the model is that the stochastic structure underlying the returns on the two assets is specified to be bivariate normal. The assumption of bivariate normality is relaxed in Section 3 where the bivariate generalized normal distribution is specified to allow for contagious channels operating through higher order moments and comoments during periods of financial crises. To investigate the effects of these additional channels of contagion on exchange options, a bivariate generalized lognormal distribution is introduced to model the joint stochastic behaviour of the underlying asset prices at the time the option contract matures. The results show that changes in coskewness can change the mass of the joint probability distribution of prices, resulting in changes in the probabilities of the payoffs and, in turn, the price of the options. The analysis is extended in Section 4 where the effects on hedging strategies are discussed in the presence of contagion during financial crises. Concluding comments and implications

for portfolio management during financial crises are provided in Section 5.

2 A Model of Exchange Options

An exchange option provides the right to exchange one asset for another asset (Magrabe (1978)). Consider an European exchange option which gives the holder the right to exchange asset 2 for asset 1 when the contract expires at time T . The price at time t of an exchange option (C_t) is given by the expected value of its discounted payoff

$$C_t = \exp[-r_f(T-t)] E_t[\text{Max}(P_{1,T} - P_{2,T}, 0) | s_{t+1}], \quad (1)$$

where the option contract is written in terms of exchanging asset 2 for asset 1, $P_{1,T}$ and $P_{2,T}$ are the respective prices of assets 1 and 2 at maturity and r_f is the risk-free rate of interest. The operator $E_t[\cdot]$ represents the conditional expectations based on information at time t and the states of nature s_{t+1} .

The exchange option price formulation is similar to a call option written on asset 1, only that the strike price is stochastic and depends directly on the price of asset 2. The value of the exchange option depends on the spread between the asset prices of 1 and 2. As the ratio of asset prices P_1/P_2 falls, the value of holding an exchange option falls. The holder of the exchange option is betting that the price of asset 1 will rise relative to 2. The opposite is true for the seller of the exchange option who is obligated to give up asset 1 in exchange for asset 2 from the option holder if the option is exercised.

For the Black-Scholes option price model, asset prices are assumed to follow geometric Brownian motion. Under risk neutrality the stochastic differential equation of asset prices is specified as

$$dP_i = (r_f - q_i) P_i dt + \sigma_i P_i dW_i, \quad (2)$$

where q_i is the dividend yield, σ_i is the instantaneous volatility of the returns on the i th asset, and W_i is a Wiener process with the property that $dW_i \sim N(0, dt)$ and $E[dW_i dW_j] = \rho dt$ allows for the Wiener processes to be correlated.

Given equations (1) and (2), the Black-Scholes price of the exchange option (Margrabe (1978), Hull (2000)), is

$$C_t^{BS} = P_{1,t} \exp(-q_1(T-t))N(d_1) - P_{2,t} \exp(-q_2(T-t))N(d_2), \quad (3)$$

where $P_{1,t}$ and $P_{2,t}$ are the underlying asset prices at time t , and q_1 and q_2 are the respective dividend yields which for simplicity are assumed to be constant over the life of the contract. The variables d_1 and d_2 are given by

$$d_1 = \frac{\ln(P_{1,t}/P_{2,t}) + (q_2 - q_1 + \sigma^2/2)(T-t)}{\sigma\sqrt{T-t}} \quad (4)$$

and

$$d_2 = d_1 - \sigma\sqrt{T-t}, \quad (5)$$

with $N(\cdot)$ representing the cumulative probability density function of a variable that is normally distributed with zero mean and a standard deviation of one, and

$$\sigma = \sqrt{\sigma_1^2 + \sigma_2^2 - 2\rho\sigma_1\sigma_2}, \quad (6)$$

where σ_1 and σ_2 are the associated volatilities of assets 1 and 2 respectively and ρ measures the correlation between assets 1 and 2.

3 Option Pricing During Financial Crises and Contagion

This section investigates the effects of financial crises and contagion on the price of exchange options between two assets, where an additional crisis transmission channel between assets exists that operates through higher order comoments of asset returns. The normality assumption underlying asset returns as embodied in the Wiener process in the Black-Scholes framework of equation (2) is extended by specifying the following

generalized normal distribution (Fry, Martin and Tang (2010))¹

$$f(r_{1,t}, r_{2,t}) = \exp [\theta_1 r_{1,t}^2 + \theta_2 r_{2,t}^2 + \theta_3 r_{1,t} r_{2,t} + \theta_4 r_{1,t}^3 + \theta_5 r_{1,t}^2 r_{2,t} + \theta_6 r_{1,t} r_{2,t}^2 + \theta_7 r_{2,t}^3 + \theta_8 r_{1,t}^4 + \theta_9 r_{2,t}^4 - \eta], \quad (7)$$

where

$$r_{i,t} = \ln P_{i,t} - \ln P_{i,t-1} \quad (8)$$

is the log-return at time t on the i^{th} asset, η is the normalizing constant with the property

$$\int \int f(r_1, r_2) dr_1 dr_2 = 1, \quad (9)$$

and $\theta_i, i = 1, 2, \dots, 9$, are parameters.

An important special case of the generalized normal distribution in equation (7) is that it contains the bivariate normal distribution as a special case when the following restrictions are imposed

$$\theta_1 = -\frac{0.5}{1-\rho^2}, \quad \theta_2 = -\frac{0.5}{1-\rho^2}, \quad \theta_3 = \frac{\rho}{1-\rho^2}, \quad \theta_i = 0, \forall i \geq 4, \quad (10)$$

where ρ represents the correlation parameter between r_1 and r_2 . Reflecting the statistical features of asset prices during financial crises summarized in Table 2, the parameters θ_4 and θ_7 allow for skewness in the returns of assets 1 and 2 respectively, whereas the parameters θ_8 and θ_9 allow for kurtosis in assets 1 and 2 respectively. Coskewness is captured by the parameters θ_5 and θ_6 . The first form of coskewness as represented by the term $r_{1,t}^2 r_{2,t}$, captures the interaction effect between the volatility of returns in asset 1 and the mean in asset 2, while the second form of coskewness as represented by the term $r_{1,t} r_{2,t}^2$, is the reverse, capturing the interaction effect between the mean of returns in asset 1 and the volatility in asset 2.²

¹The bivariate generalized normal distribution is an extension of the generalized normal distribution investigated by Lye and Martin (1993).

²To allow for cokurtosis in the generalized normal distribution given in equation (7) the terms $r_1 r_2^3$, $r_1^2 r_2^2$ and $r_1^3 r_2$ can also be included.

3.1 The Bivariate Generalized Lognormal Distribution

In pricing options what is of interest is the joint distribution of prices over the life of the exchange options contract. Given the returns distribution in (7), the price distribution is obtained by using the transformation of variable technique

$$g(P_{1,t}, P_{2,t}) = |J| f(\ln P_{1,t} - \ln P_{1,t-1}, \ln P_{2,t} - \ln P_{2,t-1}) \quad (11)$$

where

$$|J| = \left| \frac{1}{P_{1,t}P_{2,t}} \right| \quad (12)$$

is the absolute value of the Jacobian using the transformation in (8). Using this expression for the Jacobian in (11), the bivariate distribution of prices conditional on lagged prices is then given by

$$\begin{aligned} g(P_{1,t}, P_{2,t} | P_{1,t-1}, P_{2,t-1}) = & \exp \left[\theta_1 (\ln P_{1,t} - \ln P_{1,t-1})^2 + \theta_2 (\ln P_{2,t} - \ln P_{2,t-1})^2 \right. \\ & + \theta_3 (\ln P_{1,t} - \ln P_{1,t-1}) (\ln P_{2,t} - \ln P_{2,t-1}) \\ & + \theta_4 (\ln P_{1,t} - \ln P_{1,t-1})^3 \\ & + \theta_5 (\ln P_{1,t} - \ln P_{1,t-1})^2 (\ln P_{2,t} - \ln P_{2,t-1}) \\ & + \theta_6 (\ln P_{1,t} - \ln P_{1,t-1}) (\ln P_{2,t} - \ln P_{2,t-1})^2 \\ & + \theta_7 (\ln P_{2,t} - \ln P_{2,t-1})^3 + \theta_8 (\ln P_{1,t} - \ln P_{1,t-1})^4 \\ & \left. + \theta_9 (\ln P_{2,t} - \ln P_{2,t-1})^4 - \eta \right] \frac{1}{P_{1,t}P_{2,t}}. \quad (13) \end{aligned}$$

An important special case of (13) is obtained by imposing the bivariate normal restrictions in (10) as the conditional price distribution reduces to the bivariate lognormal distribution. Higher order comoments can be included in the bivariate distribution by now allowing $\theta_i \neq 0$, $i \geq 4$. For this reason, the conditional price distribution in (13) represents a generalized lognormal distribution.

The properties of the generalized lognormal distribution in (13) are highlighted in Figure 1 which gives both surface and contour plots for alternative parameterizations.

For all parameterizations, conditioning is chosen as $\ln P_{1,t-1} = \ln P_{2,t-1} = 1$, while $\rho = 0$. The normalizing constant η in (13) is computed using the procedure INTQUAD2 in Gauss 10 which evaluates a double integral by Gaussian quadrature. As a check on the numerical integrations, in the case of bivariate lognormality, the percentage error in computing the normalizing constant η in (13) by numerical integration is around 2% for alternative values of σ_1, σ_2 and ρ , compared to the analytical expression of $\ln(2\pi\sigma_1\sigma_2(1-r^2)^{0.5})$.

The bivariate lognormal distribution given in Figures 1(a) and (b) is generated by imposing the restrictions in (10). As $\rho = 0$, the two prices, $P_{1,t}$ and $P_{2,t}$, are independently distributed with the joint distribution exhibiting a single peak. In the context of exchange options whereby the contract is only exercised when $P_{1,T} > P_{2,T}$, the pertinent area of the probability space in Figure 1 is represented by the area below a 45° line in the contour diagrams.

Resetting the parameters that control the highest even moments to $\theta_8 = \theta_9 = -0.25$, while still using the same parameter values for θ_1, θ_2 and θ_3 results in a more peaked joint price distribution in Figures 1(c) and (d). The effects of coskewness are highlighted in the remaining plots in Figure 1 by changing the value of θ_5 , while imposing the restrictions of the following

$$\theta_1 = \theta_2 = -0.5, \quad \theta_3 = 0.0, \quad \theta_4 = 0.0, \quad \theta_6 = \theta_7 = 0, \quad \theta_8 = \theta_9 = -0.25.$$

In Figures 1(e) and (f), the coskewness parameter is $\theta_5 = -0.5$ which has the effect of stretching the distribution in the direction of $P_{1,t}$ resulting in the distribution of $P_{1,t}$ conditional on $P_{2,t}$ exhibiting longer tails especially where conditioning corresponds to relatively low values of $P_{2,t}$. This result occurs because for relatively low values of $P_{2,t}$, the “mean” part of the coskewness term given by $\ln P_{2,t} - \ln P_{2,t-1}$, is negative by definition. Combining this with the fact that $\theta_5 < 0$, shows that for relatively low values of $P_{2,t}$, the sign on the “variance” part of the coskewness term given by $(\ln P_{1,t} - \ln P_{1,t-1})^2$, is positive. As $(\ln P_{1,t} - \ln P_{1,t-1})^2 > 0$ for all values of $P_{1,t}$, the

joint price distribution is stretched in the direction of $P_{1,t}$. By changing the coskewness parameter to $\theta_5 = -0.8$, Figures 1(g) and (h) show that there is even more stretching of the joint price distribution in the direction of $P_{1,t}$.

In Figures 1(i) and (j), the coskewness parameter is set at $\theta_5 = 0.5$, which is increased to $\theta_5 = 0.8$ in Figures 1(k) and (l). In these two cases, there is now stretching in the $P_{2,t}$ direction for relatively low values of $P_{1,t}$. This arises because for relatively “large” values of $P_{2,t}$, the “mean” part of the coskewness term given by $\ln P_{2,t} - \ln P_{2,t-1}$, is positive and when combined with $\theta_5 > 0$ and $(\ln P_{1,t} - \ln P_{1,t-1})^2 > 0$, the net effect is a positive effect on the joint price distribution in the direction of $P_{2,t}$.

3.2 The Effects on Exchange Options of Coskewness in the Expiration Distribution

There are two natural ways that the generalized bivariate lognormal price distribution can be introduced into the exchange options model. The first is through the generating process of the joint distribution of returns on the two assets over the life of the exchange option contract and the second is through the specification of the joint price distribution at the time of maturity, namely for $P_{1,T}$ and $P_{2,T}$ where T is the maturity date of the contract. In this section, the latter is discussed with special emphasis on the effects of coskewness on the terminal distribution and the corresponding effects on the price of the exchange option contract written at time t . The former case is discussed in the following section.

Consider the following bivariate generalized lognormal (conditional) distribution corresponding to the prices at maturity

$$g(P_{1,T}, P_{2,T} | P_{1,t}, P_{2,t}) = \exp [\theta_1 z_1^2 + \theta_2 z_2^2 + \theta_3 z_1 z_2 + \theta_4 z_1^3 + \theta_5 z_1^2 z_2 + \theta_6 z_1 z_2^2 + \theta_7 z_2^3 + \theta_8 z_1^4 + \theta_9 z_2^4 - \eta] \frac{1}{P_{1,t} P_{2,t}}, \quad (14)$$

where the coskewness parameters θ_5 and θ_6 have the values

$$\theta_5 = \{0, -0.8, 0.8\}, \quad \theta_6 = \{0, -0.3, 0.3\},$$

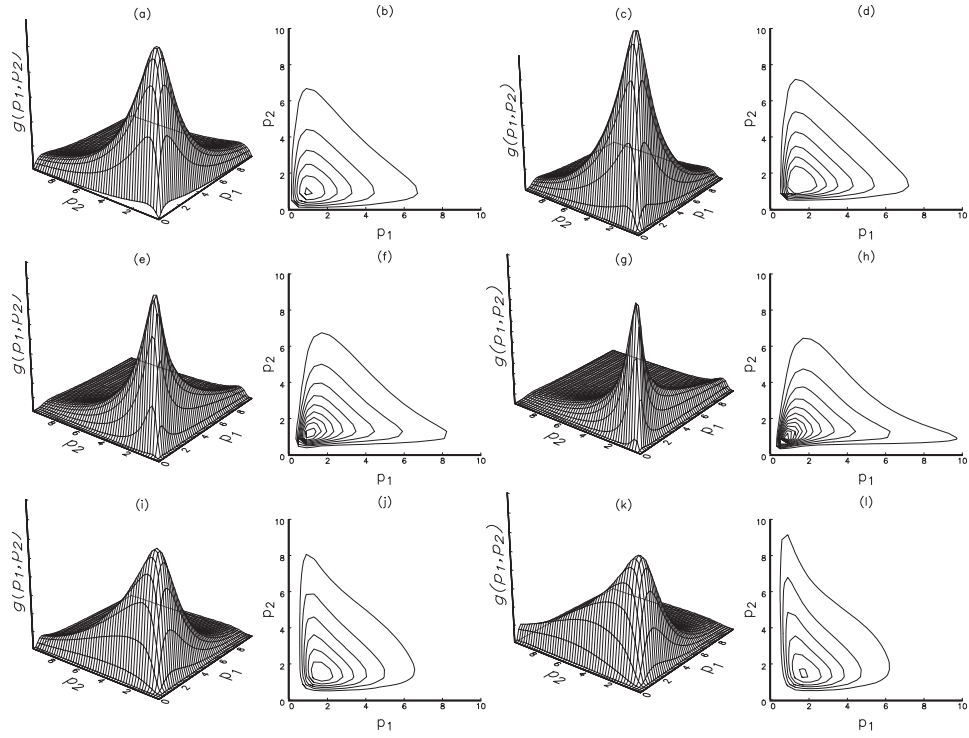

Figure 1: Generalized joint lognormal price distributions, as given in equation (13).

	θ_1	θ_2	θ_3	θ_4	θ_5	θ_6	θ_7	θ_8	θ_9
a,b	-0.5	-0.5	0.0	0.0	0.0	0.0	0.0	0.0	0.0
c,d	-0.5	-0.5	0.0	0.0	0.0	0.0	0.0	-0.25	-0.25
e,f	-0.5	-0.5	0.0	0.0	-0.5	0.0	0.0	-0.25	-0.25
g,h	-0.5	-0.5	0.0	0.0	-0.8	0.0	0.0	-0.25	-0.25
i,j	-0.5	-0.5	0.0	0.0	0.5	0.0	0.0	-0.25	-0.25
k,l	-0.5	-0.5	0.0	0.0	0.8	0.0	0.0	-0.25	-0.25

while the remaining parameters are set at

$$\theta_1 = -\frac{0.5}{1-\rho^2}, \quad \theta_2 = -\frac{0.5}{1-\rho^2}, \quad \theta_3 = \frac{\rho}{1-\rho^2}, \quad \theta_4 = 0.0, \quad \theta_6 = \theta_7 = 0, \quad \theta_8 = \theta_9 = -0.25.$$

In the case of the exchange options model in Section 2, the standardised random variables $z_{1,T}$ and $z_{2,T}$, in (14) are chosen as

$$\begin{aligned} z_{1,T} &= \frac{\ln P_{1,T} - \ln P_{1,t} - (rf - q_1 - 0.5\sigma_1^2)(T-t)}{\sigma_1\sqrt{(T-t)}} \\ z_{2,T} &= \frac{\ln P_{2,T} - \ln P_{2,t} - (rf - q_2 - 0.5\sigma_2^2)(T-t)}{\sigma_2\sqrt{(T-t)}}, \end{aligned} \quad (15)$$

where all terms are as defined in Section 2.

The price of the exchange option is then given by

$$C_t^{GN} = \exp[-r_f(T-t)] \int_0^\infty \int_{P_{2,T}}^\infty (P_{1,T} - P_{2,T}) g(P_{1,T}, P_{2,T} | P_{1,t}, P_{2,t}) dP_{1,T} dP_{2,T}, \quad (16)$$

with the range of integration of $P_{1,T}$ being from $P_{2,T}$ to ∞ , ensuring that only probabilities where

$$P_{1,T} > P_{2,T}$$

are considered in the evaluation of the exchange option. This choice of $z_{1,T}$ and $z_{2,T}$ in (15) is adopted as the exchange options price C_t^{GN} is equivalent to the Black-Scholes price given in (3) under the assumption of bivariate lognormality, that is, $\theta_i = 0$, $i \geq 4$. For general parameterizations of the generalized bivariate lognormal distribution $g(P_{1,T}, P_{2,T} | P_{1,t}, P_{2,t})$, the evaluation of the integrals in (16) cannot be evaluated analytically as in the case of the Black-Scholes exchange option price. Instead these integrals are computed numerically using the Gaussian quadrature procedure INTGRAT2 in GAUSS 10.

As a test of the quality of the numerical integrations, the exchange option price in the case of bivariate lognormality is computed using the analytical expression in (3) and compared to two prices based on numerical integration. The first numerically integrated option price uses the analytical form of the normalizing constant of the bivariate

lognormal distribution while computing the double integrals in (16) numerically. The second numerically integrated option price uses the numerical form of the normalizing constant of the bivariate lognormal distribution while still computing the double integrals in (16) numerically as well. Using as inputs into the exchange option

$$\begin{aligned} P_{1,t} = P_{2,t} = 1, \quad q_1 = 0.04, \quad q_2 = 0.05, \quad r_f = 0.1, \\ T - t = 1, \quad \sigma_1 = \sigma_2 = 0.2, \quad \rho = 0.5, \end{aligned} \quad (17)$$

the three exchange option prices are:

Analytical	= 0.0810264353
Numerical with normalizing constant evaluated analytical	= 0.0810264356
Numerical with normalizing constant evaluated numerical	= 0.0810208315

The numerical price which uses the analytical expression of the normalizing constant in the bivariate lognormal distribution is accurate to the 6th decimal place. In the case where the option price is computed where both the normalizing constant η and the double integrals in (16) are evaluated numerically, the exchange option price is accurate to the 5th decimal place.

Table 3 gives the exchange option prices based on (16) for alternative values of the coskewness parameters θ_5 and θ_6 , with the exchange option inputs given in (17). The effect of increasing negative coskewness by allowing for larger negative values of θ_5 , results in the joint generalized lognormal distribution stretching along the $P_{1,T}$ axis. This raises the probability of higher payoffs, $P_{1,T} - P_{2,T}$, which, in turn, leads to higher option prices. The same qualitative result occurs for increasing negative skewness through larger negative values of θ_6 . In the case of positive coskewness, through either positive increases in θ_5 or θ_6 , the mass of the joint distribution now moves in the direction of $P_{2,T}$ with the joint distribution stretching along the $P_{2,T}$ axis. This corresponds to higher probabilities of lower payoffs, resulting in lower prices for exchange options.

Table 3:

The price of exchange options in (16) for alternative levels of coskewness in the expiration bivariate price distribution in (14). Exchange option inputs are based on (17) with the parameters of the bivariate generalized lognormal distribution set at

$$\theta_1 = -\frac{0.5}{1-\rho^2}, \theta_2 = -\frac{0.5}{1-\rho^2}, \theta_3 = \frac{\rho}{1-\rho^2}, \theta_4 = 0.0, \theta_7 = 0, \theta_8 = \theta_9 = -0.1.$$

θ_5	Option Price, C_t^{GN}	θ_6	Option Price, C_t^{GN}
0.0	0.0673	0.0	0.0673
-0.2	0.0708	-0.2	0.0684
-0.4	0.0731	-0.4	0.0701
0.2	0.0642	0.2	0.0663
0.4	0.0633	0.4	0.0653

3.3 Pricing by Monte Carlo Methods

To compute the option price in equation (1) assuming that returns at each point in time over the life of the contract from t to T , are based on either the bivariate generalized normal distribution in (7) or the bivariate generalized lognormal distribution in (14), an analytical solution is not available. One approach is to use Monte Carlo methods to compute the option prices. The steps involved consist of replacing the conditional expectation in equation (1) by simulating the asset price equation $H = 10,000$ times using a discrete time step, and assuming that the disturbances are drawn from the generalized normal distribution in equation (7). The option price is then computed as the discounted payoff of the sample mean of the simulation runs

$$C_t^{GN} = \exp[-r_f(T-t)] \frac{1}{H} \sum_{i=1}^H \text{Max}(P_{1,T}^i - P_{2,T}^i, 0). \quad (18)$$

To improve the accuracy of the simulated option price, a control variate is used by augmenting the generalized normal distribution option price in equation (18) by the difference between the analytical Black-Scholes price and the Monte Carlo price based on bivariate normality.

To determine the effects of contagion during a financial crisis on the price of exchange options, two simulation experiments are conducted. As a benchmark the price of exchange options during the noncrisis period are assumed to correspond to the Black-Scholes price whereby the Weiner processes of the two underlying assets the exchange option contract is written on, follow a bivariate normal distribution. The exchange option prices are evaluated using the following inputs

$$\begin{aligned} q_1 &= 0.04, & q_2 &= 0.05, & r_f &= 0.1, \\ T - t &= 1, & \sigma_1 &= \sigma_2 = 0.2, & \rho &= 0.5, \end{aligned} \tag{19}$$

with the prices of asset 1 and asset 2 at time t taking on values between 60 and 100 in increments of 5

$$\begin{aligned} P_{1,t} &= \{60, 65, \dots, 95, 100\}, \\ P_{2,t} &= \{60, 65, \dots, 95, 100\}. \end{aligned}$$

During the period of the financial crisis, additional contagious channels arise through the higher order moments by assuming that the disturbances of the prices of the underlying assets follow a generalized normal distribution. To determine the potential size of mispricing during the crisis period from ignoring the nonnormalities in returns, the Black-Scholes prices are also computed in the crisis period using the implied volatility and correlation of the returns based on the generalized normal distribution. The results of two experiments are now presented.

3.3.1 Experiment 1

As Table 1 shows that returns during the financial crises tend to exhibit positive skewness and coskewness, the bivariate generalized normal distribution is parameterized accordingly in the following experiments. In the first experiment, the parameters of

the generalized normal distribution in equation (7) during the crisis period are

$$\begin{aligned}
\theta_1 &= \theta_2 = -\frac{0.5}{1-\rho^2}, & \theta_3 &= \frac{\rho}{1-\rho^2}, \\
\theta_4 &= 0.0, & \theta_5 &= 0.0, & \theta_6 &= 0.7, \\
\theta_7 &= 0.0, & \theta_8 &= \theta_9 = -0.1,
\end{aligned} \tag{20}$$

with $\rho = 0.5$, which yields positive coskewness of 0.270 during the crisis period compared to a value of zero coskewness in the noncrisis case. The noncrisis distribution of returns is represented by the standardized bivariate normal distribution with zero means, unit variances and correlation $\rho = 0.5$, which is obtained by imposing the additional restrictions $\theta_i = 0$, $i \geq 4$, on the parameters in equation (7).

To determine the potential size of mispricing during the crisis period from ignoring coskewness in returns, two exchange option prices are computed. The first is the Black-Scholes price using equation (3). In computing this price in the crisis period the parameter values for volatility and correlation are taken as the implied values associated with the bivariate generalized normal returns distribution. Formally, this is achieved by computing

$$\begin{aligned}
\sigma_1^2 &= \int \int (r_1 - \mu_1)^2 f(r_1, r_2) dr_1 dr_2 = 0.964^2 \\
\sigma_2^2 &= \int \int (r_2 - \mu_2)^2 f(r_1, r_2) dr_1 dr_2 = 1.122^2 \\
\sigma_{1,2} &= \int \int (r_1 - \mu_1)(r_2 - \mu_2) f(r_1, r_2) dr_1 dr_2 = 0.727,
\end{aligned}$$

where the means are computed as

$$\mu_i = \int \int r_i f(r_1, r_2) dr_1 dr_2, \quad i = 1, 2.$$

The value of the correlation parameter increases from 0.5 during the noncrisis period to

$$\rho = \frac{\sigma_{1,2}}{\sigma_1 \sigma_2} = 0.672,$$

during the crisis period. The second price computed is the generalized normal exchange option price based on (18), by simulating the two asset prices 10,000 times over the life of the contract equal to 1 year in steps of $\Delta t = 0.1$.

The results of the simulation experiment are presented in Figure 2 with the Black-Scholes price (C_t^{BS}) given in Figure 2(a) and the generalized normal distribution price (C_t^{GN}) given in Figure 2(b). Inspection of the two graphs shows that option prices computed according to C_t^{BS} during a financial crisis understate the true price as represented by C_t^{GN} , for all underlying asset price pairs under consideration.

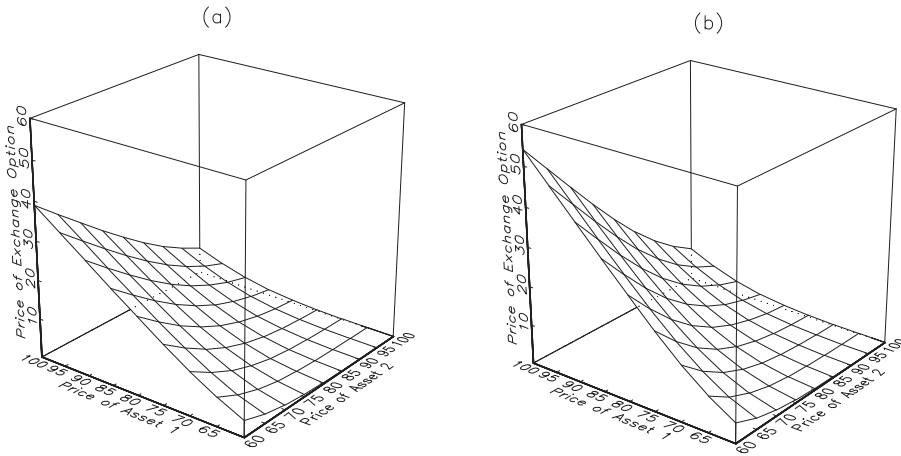

Figure 2: Option prices during a financial crisis based on the parameterizations in (20). Part (a) gives the Black-Scholes price C_t^{BS} , part (b) gives the Generalized normal price C_t^{GN} .

Figure 3 shows the extent of underpricing of exchange options in absolute and percentage terms. Figure 3(a) reveals that the extent of underpricing in absolute terms becomes higher as the exchange option moves from being out-of-the-money towards being in-the-money. Inspection of the option prices generated reveals that the absolute size of underpricing are on average, -0.35 , -1.21 and -5.77 , when the options are out-of-the-money, at-the-money and in-the-money respectively.

The size of underpricing in percentage terms across the various asset price pairs under consideration can be seen in Figure 3(b). On average, the exchange option price

is understated by -29.47% , -17.77% and -23.00% when the options are out-of-the-money, at-the-money and in-the-money respectively. Overall, for all the underlying asset price pairs under consideration, the Black-Scholes prices in the crisis period underprices exchange options by 25.30% when compared to C_t^{GN} , the price which correctly allows for positive coskewness in the crisis period.

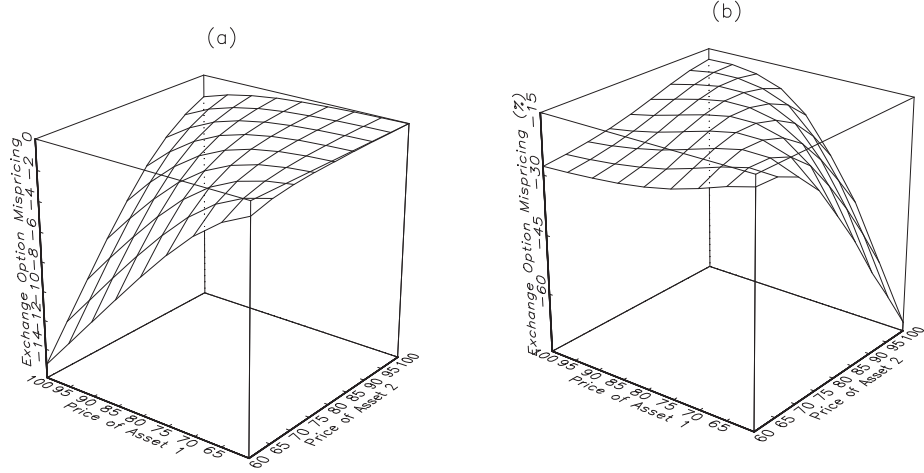

Figure 3: Mispricing error of Black-Scholes during a financial crisis, based on the parameterizations in (20). Part (a) is $C_t^{BS} - C_t^{GN}$, while part (b) gives $(C_t^{BS}/C_t^{GN} - 1) \times 100$.

Figure 4 provides cross-sectional views of the exchange option prices computed using C_t^{BS} and those generated based on C_t^{GN} , for selected prices of assets 1 and 2. Panel (a) provides the results for price pairs for $P_1 = \{60, 80, 100\}$ with P_2 ranging from 60 to 100, while panel (b) is based on the price pairs for $P_2 = \{60, 80, 100\}$ with P_1 ranging from 60 to 100. For given price levels of asset 1, the size of underpricing increases as the price of asset 2 falls from 100 to 60 in Panel (a) of Figure 4. Similarly, for given price levels of asset 2, the size of underpricing increases as the price of asset

1 rises from 60 to 100 in Panel (b) of Figure 4.

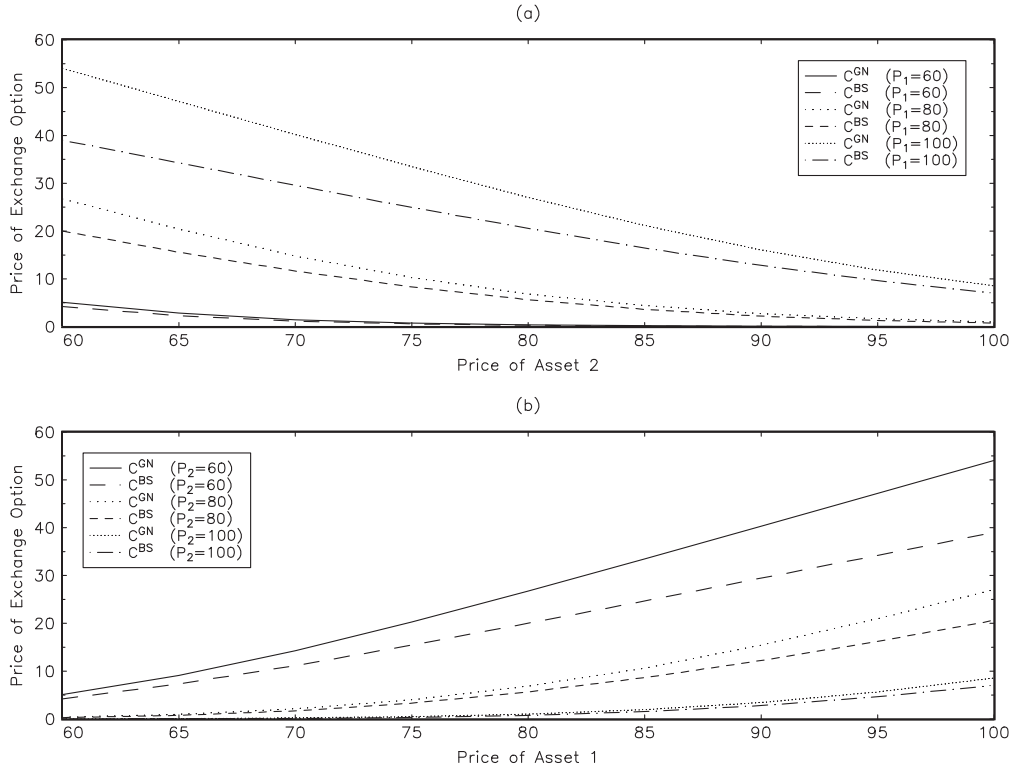

Figure 4: Exchange option prices for generalized normal C_t^{GN} and Black-Scholes C_t^{BS} cases corresponding to various asset price pairs based on the parameterizations in (20).

3.3.2 Experiment 2

In the second experiment, an alternative form of coskewness is chosen to the one given in experiment 1 by specifying the parameters of the generalized normal distribution in the crisis period as

$$\begin{aligned}
 \theta_1 &= \theta_2 = -\frac{0.5}{1-\rho^2}, & \theta_3 &= \frac{\rho}{1-\rho^2}, \\
 \theta_4 &= 0.0, & \theta_5 &= 0.6, & \theta_6 &= 0.0, \\
 \theta_7 &= 0.0, & \theta_8 &= \theta_9 = -0.1,
 \end{aligned} \tag{21}$$

with $\rho = 0.5$ as before, which yields positive coskewness of 0.354 compared to a value of zero coskewness in the noncrisis case.

To compute the correlation between the two asset markets, the variances and covariance are evaluated as

$$\begin{aligned}\sigma_1^2 &= \int \int (r_1 - \mu_1)^2 f(r_1, r_2) dr_1 dr_2 = 0.969^2, \\ \sigma_2^2 &= \int \int (r_2 - \mu_2)^2 f(r_1, r_2) dr_1 dr_2 = 0.871^2, \\ \sigma_{1,2} &= \int \int (r_1 - \mu_1)(r_2 - \mu_2) f(r_1, r_2) dr_1 dr_2 = 0.466,\end{aligned}$$

where the means are computed as

$$\mu_i = \int \int r_i f(r_1, r_2) dr_1 dr_2, \quad i = 1, 2.$$

The correlation parameter during the crisis period equals

$$\rho = \frac{\sigma_{1,2}}{\sigma_1 \sigma_2} = 0.553.$$

Figure 5 shows the prices of European exchange options during the crisis period where the asset distribution is bivariate generalized normal and based on the parameterization in (21). Panel (a) gives C_t^{BS} , the Black-Scholes price which is incorrectly based on bivariate normality, while panel (b) gives C_t^{GN} , the generalized normal price which correctly allows for positive coskewness in the crisis period. The results show that C_t^{BS} misprices the exchange option across the various asset price pairs under

consideration.

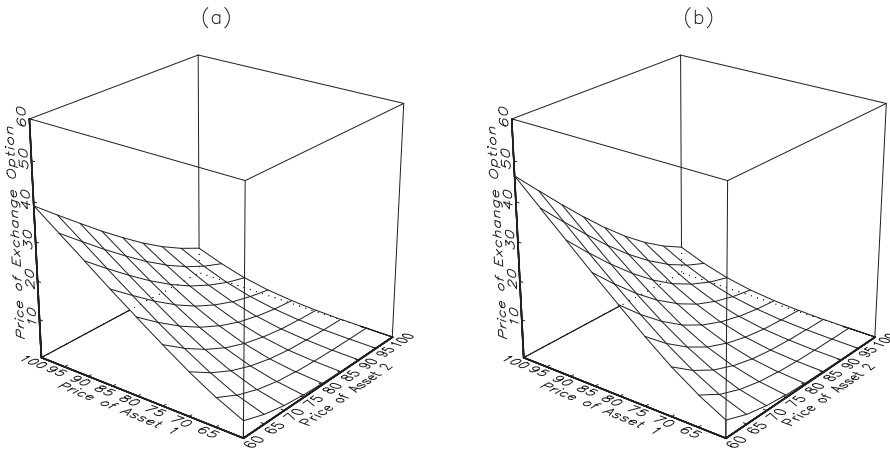

Figure 5: Option prices during a financial crisis based on the parameterizations in (21). Part (a) gives the Black-Scholes price C_t^{BS} , part (b) gives the Generalized normal price C_t^{GN} .

The extent of mispricing of exchange options, in absolute and percentage terms, is highlighted in Figure 6. Figure 6(a) reveals that in absolute terms, the exchange option is mostly underpriced when it is out-of-the-money and is also underpriced when at-the-money and in-the-money. Inspection of the option prices reveals that when the options are out-of-the-money, 64% of them are underpriced with the average size of underpricing being equal to -0.03 , with the remaining 36% overpriced with the average size of overpricing equal to 0.01 . For at-the-money and in-the-money options, the absolute size of underpricing are on average, -0.26 and -2.50 respectively.

The size of mispricing in percentage terms across the various asset price pairs under consideration is highlighted in Figure 6(b). The option prices are understated on average with few exceptions, by -9.15% (out-of-the-money), -4.29% (at-the-money)

and -10.89% (in-the-money).³

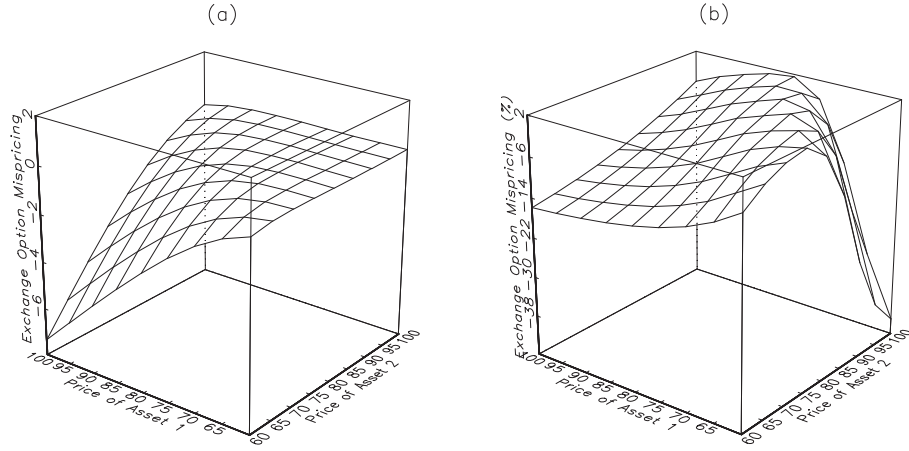

Figure 6: Mispricing error of Black-Scholes during a financial crisis, based on the parameterizations in (21). Part (a) is $C_t^{BS} - C_t^{GN}$, while part (b) gives $(C_t^{BS}/C_t^{GN} - 1) \times 100$.

Figure 7 provides a cross-sectional view of the exchange option prices computed using C_t^{BS} and those generated based on C_t^{GN} , for selected values of assets 1 and 2 under the parameterization in (21). Panel (a) is based on price pairs for $P_1 = \{60, 80, 100\}$ with P_2 ranging from 60 to 100, while panel (b) is based on the price pairs for $P_2 = \{60, 80, 100\}$ with P_1 ranging from 60 to 100. For given price levels of 80 and 100 for asset 1, the size of underpricing increases as the price of asset 2 falls from 100 to 60 in Panel (a) of Figure 7. For the price level of 60 for asset 1, the difference between the exchange option prices based on C_t^{BS} and C_t^{GN} appears to be small. In this case, the exchange option prices are either at-the-money or out-of-the-money. Similarly, for given price levels of 60 and 80 for asset 2, the size of underpricing increases as the price of asset 1 rises from 60 to 100 in Panel (b) of Figure 7. For the price level of 100 for asset 2, the difference between the exchange option prices based on C_t^{BS} and C_t^{GN} is also

³The few exceptions correspond to some out-of-the-money options with the average size of overpricing equaling 1.00%.

small. In this case, the exchange option is either at-the-money or out-of-the-money.

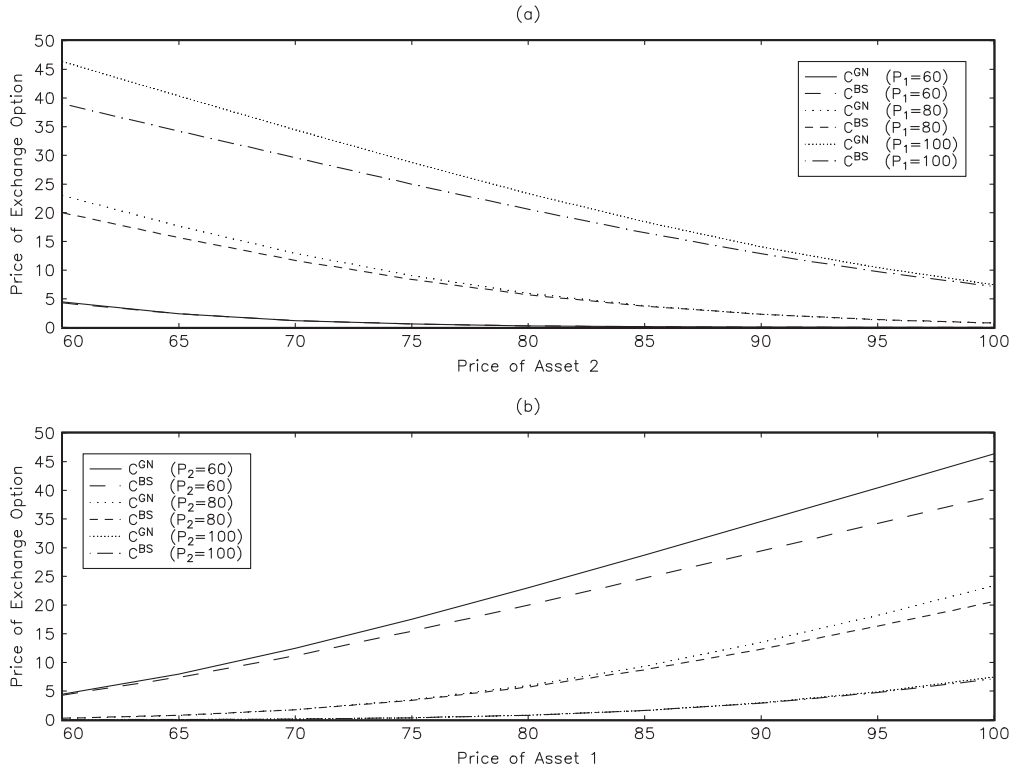

Figure 7: Exchange option prices for generalized normal C_t^{GN} and Black-Scholes C_t^{BS} corresponding to various asset price pairs based on the parameterizations in (21).

4 Portfolio Effects of Financial Crises

The risks arising from having open positions in exchange options can be hedged. A common approach to hedging an option is delta hedging where an offsetting underlying asset position equivalent to the option face value multiplied by its current delta is taken. For a call option, the delta is simply given as the change in the call option value with respect to a change in the asset price. When an offsetting delta equivalent position is held against an option position, the overall position is considered delta neutral. In this situation, the combined option and hedge position will show no profit or loss for small changes in the underlying asset price (see Hull, 1970). The deltas of the exchange option with respect to the two underlying assets can likewise be derived

from the pricing equation in (3) so that offsetting positions may be taken in each of the respective assets to hedge against the underlying sources of price risks. In this section, deltas derived analytically from the Black-Scholes pricing equation in (3) are computed for a selected range of prices for the underlying assets. These deltas which are computed based on the assumption of bivariate normality are then compared to the deltas computed from numerically generated exchange option prices that take into account of higher order comoments, including coskewness during the crisis period. The difference in the analytical and simulated deltas correspond to the hedging errors that may result from using the Black-Scholes option pricing equation in the presence of coskewness during periods of financial crisis and contagion. In presenting the delta results, the two simulation experiments performed in the previous section are adopted again.

The deltas of the Black-Scholes exchange option with respect to the underlying assets 1 and 2, are obtained by differentiating equation (3) with respect to $P_{1,t}$ and $P_{2,t}$, the prices of the two assets (see Appendix A for details). They are given as

$$\frac{\partial C^{BS}}{\partial P_{1,t}} = \exp(-q_1(T-t))N(d_1), \quad (22)$$

$$\frac{\partial C^{BS}}{\partial P_{2,t}} = -\exp(-q_2(T-t))N(d_2). \quad (23)$$

In the case of the generalized normal option price in (18), the deltas need to be computed numerically. Using a step interval of 1, the numerical derivatives to compute the delta for each asset are as follows

$$\left. \frac{\partial C^{GN}}{\partial P_{1,t}} \right|_{P_1=j, P_2=j+k} = C^{GN}|_{P_1=j+1, P_2=j+k} - C^{GN}|_{P_1=j, P_2=j+k}, \quad (24)$$

$$\left. \frac{\partial C^{GN}}{\partial P_{2,t}} \right|_{P_1=j, P_2=j+k} = C^{GN}|_{P_1=j, P_2=j+k+1} - C^{GN}|_{P_1=j, P_2=j+k}, \quad (25)$$

where

$$j = \{60, 70, 80, 90, 100\},$$

$$k = \{-20, -15, -10, -5, 0, 5, 10, 15, 20\}.$$

Table 4 presents the deltas in (22) to (25) for various asset price pairs using the parameterization in experiment 1 given in (20). The deltas are computed for $P_1 = \{60, 70, 80, 90, 100\}$, each paired with prices of asset 2 that are higher than the level of P_1 to a maximum of 20 at increments of 5, equal to the level of P_1 and lower than P_1 to a maximum of 20 at intervals of 5. These scenarios correspond to the exchange option being out-of-the money, at-the money and in-the-money respectively.

The deltas corresponding to asset 1 are positive as increases in the price of the underlying asset 1 provides the holder of the exchange option with the right to exchange asset 2 for the now more valuable asset 1. The deltas corresponding to asset 2 are negative as increases in the price of the underlying asset 2 decreases the value of the exchange option as one has to give up a now more valuable asset 2 in exchange for asset 1 in exercising the option.

As the exchange option moves from being out-of-the-money to being in-the-money, the value of delta with respect to P_1 becomes larger while the value of delta with respect to P_2 becomes more negative. This is the case for deltas based on the Black-Scholes pricing equation as well as those based on the generalized normal exchange option price.

Across all asset price pairs under consideration, the positive deltas generated for the generalized normal exchange option prices are larger than the deltas based on Black-Scholes. As for the deltas of exchange options with respect to P_2 , the deltas corresponding to the generalized normal option prices are consistently more negative than those based on Black-Scholes. Moreover, for certain price pairs, the delta associated with the generalized normal options are greater in absolute terms than unity. In contrast, and by construction, the deltas associated with the Black-Scholes options are all between 0.0 and 1.0. This result suggests that during financial crises, the incorrect adoption of Black-Scholes delta hedging may lead to an under-estimate in absolute terms of the quantities needed of the underlying assets in the portfolio.

Inspection of Figure 8 reveals that as the exchange option moves from out-of-the-money to in-the-money, the level of the differences in the deltas computed based on the generalized normal and Black-Scholes option prices, rises nonlinearly. When the exchange option is in-the-money, the level of the differences in the deltas is higher at lower values of P_1 for each given value of $P_1 - P_2$. The reverse occurs when the exchange option is out-of-the-money, suggesting the presence of a level effect.

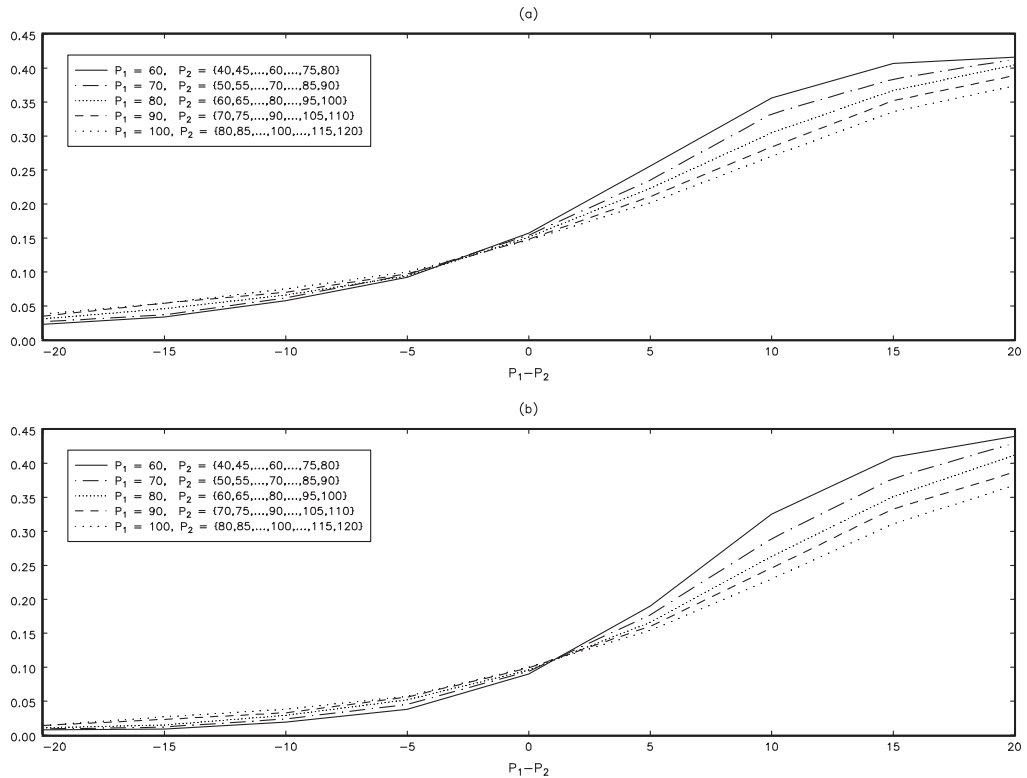

Figure 8: Differences between generalized normal and Black-Scholes deltas using the parameterization in (20). In Panel (a), the generalized normal delta is based on (24) and the Black-Scholes delta is based on (22) for asset 1. In Panel (b), the generalized normal delta is based on (25) and the Black-Scholes delta is based on (23) for asset 2.

The results for the Black-Scholes and generalized normal deltas based on the second experiment using the parameterization in (21), are given in Table 5 using the same pairs of prices as that used in Table 4. A comparison of Tables 4 and 5 shows that the deltas based on Black-Scholes option prices for both assets are fairly insensitive to

Table 4:

Deltas corresponding to asset price pairs based on the parameterizations given in (20).

	$P_1 - P_2$									
	-20	-15	-10	-5	0	5	10	15	20	
$P_1 = 60$										
$\frac{\partial C^{BS}}{\partial P_1}$	0.060	0.119	0.216	0.359	0.535	0.714	0.852	0.928	0.955	
$\frac{\partial C^{GN}}{\partial P_1}$	0.083	0.153	0.274	0.451	0.692	0.970	1.208	1.335	1.371	
$\frac{\partial C^{BS}}{\partial P_2}$	-0.042	-0.087	-0.168	-0.295	-0.465	-0.651	-0.809	-0.904	-0.942	
$\frac{\partial C^{GN}}{\partial P_2}$	-0.050	-0.096	-0.187	-0.333	-0.555	-0.841	-1.134	-1.313	-1.382	
$P_1 = 70$										
$\frac{\partial C^{BS}}{\partial P_1}$	0.089	0.155	0.252	0.382	0.535	0.690	0.818	0.903	0.944	
$\frac{\partial C^{GN}}{\partial P_1}$	0.116	0.192	0.314	0.478	0.689	0.925	1.151	1.287	1.357	
$\frac{\partial C^{BS}}{\partial P_2}$	-0.064	-0.117	-0.200	-0.317	-0.465	-0.625	-0.769	-0.872	-0.926	
$\frac{\partial C^{GN}}{\partial P_2}$	-0.073	-0.129	-0.224	-0.362	-0.559	-0.802	-1.058	-1.250	-1.356	
$P_1 = 80$										
$\frac{\partial C^{BS}}{\partial P_1}$	0.119	0.188	0.282	0.401	0.535	0.671	0.790	0.877	0.928	
$\frac{\partial C^{GN}}{\partial P_1}$	0.150	0.234	0.348	0.495	0.686	0.894	1.095	1.244	1.333	
$\frac{\partial C^{BS}}{\partial P_2}$	-0.087	-0.144	-0.226	-0.334	-0.465	-0.606	-0.736	-0.839	-0.904	
$\frac{\partial C^{GN}}{\partial P_2}$	-0.098	-0.159	-0.255	-0.386	-0.561	-0.772	-0.999	-1.190	-1.316	
$P_1 = 90$										
$\frac{\partial C^{BS}}{\partial P_1}$	0.146	0.216	0.306	0.415	0.535	0.657	0.766	0.852	0.909	
$\frac{\partial C^{GN}}{\partial P_1}$	0.181	0.270	0.376	0.512	0.683	0.868	1.050	1.204	1.298	
$\frac{\partial C^{BS}}{\partial P_2}$	-0.110	-0.168	-0.248	-0.348	-0.465	-0.590	-0.709	-0.809	-0.880	
$\frac{\partial C^{GN}}{\partial P_2}$	-0.124	-0.191	-0.281	-0.404	-0.564	-0.750	-0.955	-1.142	-1.267	
$P_1 = 100$										
$\frac{\partial C^{BS}}{\partial P_1}$	0.172	0.241	0.327	0.427	0.535	0.645	0.746	0.829	0.890	
$\frac{\partial C^{GN}}{\partial P_1}$	0.210	0.295	0.402	0.527	0.682	0.847	1.016	1.165	1.264	
$\frac{\partial C^{BS}}{\partial P_2}$	-0.131	-0.190	-0.266	-0.359	-0.465	-0.578	-0.686	-0.781	-0.855	
$\frac{\partial C^{GN}}{\partial P_2}$	-0.145	-0.217	-0.304	-0.416	-0.565	-0.732	-0.916	-1.092	-1.223	

the change in coskewness arising from the change in parameterizations of experiments 1 and 2. This is not the case for the deltas based on generalized option prices where the deltas corresponding to both assets are uniformly higher in absolute terms for both experiments. For example, for the at-the-money options with $P_1 = P_2 = 80$, the Black-Scholes deltas are 0.535 and 0.535 for experiments 1 and 2, whereas the corresponding generalized normal deltas are respectively 0.686 and 0.613, a reduction of over 10%.

Finally, a comparison of the Black-Scholes and generalized normal deltas in Figure 9 reveal the same qualitative patterns as they do for the deltas reported in Figure 8 for the first experiment. In particular, as the exchange option moves from out-of-the-money to in-the-money, the absolute differences in the deltas computed based on the generalized normal and Black-Scholes option prices, rises nonlinearly.

Table 5:

Deltas corresponding to asset price pairs based on the parameterizations given in (21).

	$P_1 - P_2$									
	-20	-15	-10	-5	0	5	10	15	20	
$P_1 = 60$										
$\frac{\partial C^{BS}}{\partial P_1}$	0.064	0.124	0.222	0.362	0.536	0.711	0.848	0.925	0.954	
$\frac{\partial C^{GN}}{\partial P_1}$	0.067	0.131	0.241	0.399	0.618	0.841	1.021	1.129	1.174	
$\frac{\partial C^{BS}}{\partial P_2}$	-0.045	-0.091	-0.172	-0.298	-0.464	-0.647	-0.803	-0.901	-0.941	
$\frac{\partial C^{GN}}{\partial P_2}$	-0.039	-0.082	-0.165	-0.297	-0.498	-0.732	-0.954	-1.105	-1.179	
$P_1 = 70$										
$\frac{\partial C^{BS}}{\partial P_1}$	0.094	0.161	0.257	0.386	0.536	0.687	0.814	0.899	0.942	
$\frac{\partial C^{GN}}{\partial P_1}$	0.098	0.170	0.276	0.424	0.615	0.806	0.978	1.091	1.155	
$\frac{\partial C^{BS}}{\partial P_2}$	-0.068	-0.121	-0.203	-0.319	-0.464	-0.621	-0.764	-0.867	-0.924	
$\frac{\partial C^{GN}}{\partial P_2}$	-0.060	-0.112	-0.197	-0.322	-0.501	-0.701	-0.900	-1.051	-1.148	
$P_1 = 80$										
$\frac{\partial C^{BS}}{\partial P_1}$	0.124	0.193	0.287	0.403	0.536	0.669	0.786	0.873	0.925	
$\frac{\partial C^{GN}}{\partial P_1}$	0.129	0.207	0.307	0.441	0.613	0.781	0.937	1.052	1.129	
$\frac{\partial C^{BS}}{\partial P_2}$	-0.091	-0.148	-0.229	-0.336	-0.464	-0.602	-0.731	-0.834	-0.901	
$\frac{\partial C^{GN}}{\partial P_2}$	-0.083	-0.143	-0.225	-0.344	-0.504	-0.676	-0.852	-1.001	-1.107	
$P_1 = 90$										
$\frac{\partial C^{BS}}{\partial P_1}$	0.152	0.222	0.311	0.418	0.536	0.655	0.762	0.848	0.906	
$\frac{\partial C^{GN}}{\partial P_1}$	0.157	0.236	0.333	0.457	0.611	0.760	0.901	1.017	1.100	
$\frac{\partial C^{BS}}{\partial P_2}$	-0.114	-0.172	-0.251	-0.349	-0.464	-0.587	-0.704	-0.803	-0.875	
$\frac{\partial C^{GN}}{\partial P_2}$	-0.107	-0.169	-0.250	-0.360	-0.506	-0.659	-0.817	-0.961	-1.068	
$P_1 = 100$										
$\frac{\partial C^{BS}}{\partial P_1}$	0.177	0.246	0.331	0.429	0.536	0.643	0.742	0.825	0.886	
$\frac{\partial C^{GN}}{\partial P_1}$	0.187	0.259	0.356	0.470	0.609	0.741	0.874	0.988	1.070	
$\frac{\partial C^{BS}}{\partial P_2}$	-0.135	-0.194	-0.269	-0.360	-0.464	-0.574	-0.681	-0.776	-0.850	
$\frac{\partial C^{GN}}{\partial P_2}$	-0.129	-0.192	-0.270	-0.373	-0.508	-0.647	-0.789	-0.924	-1.029	

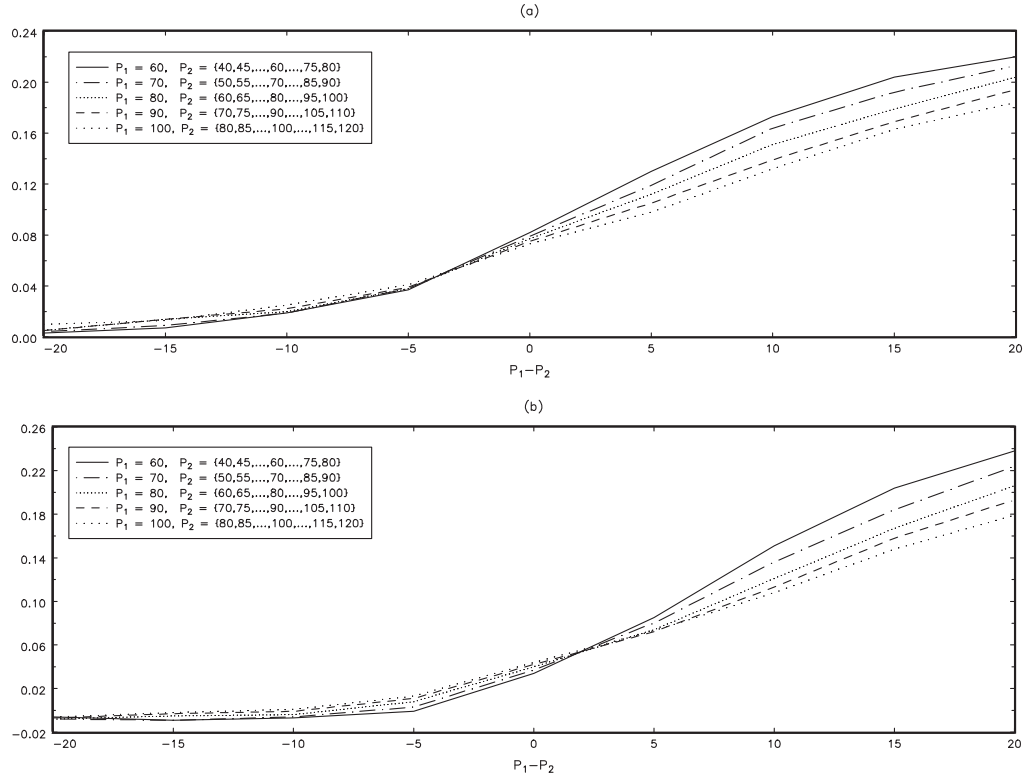

Figure 9: Differences between generalized normal and Black-Scholes deltas using the parameterization in (21). In Panel (a), the generalized normal delta is based on (24) and the Black-Scholes delta is based on (22) for asset 1. In Panel (b), the generalized normal delta is based on (25) and the Black-Scholes delta is based on (23) for asset 1.

5 Conclusions and Implications for Portfolio Management

The recent financial crises, including subprime, the Great Recession and the European debt crisis, revealed additional crisis transmission channels operating through higher order comoments of asset returns. Asset mispricing can be particularly significant during periods of financial crisis and contagion. Financial institutions which originate options such as the exchange option may engage in delta hedging in order that they earn premiums from writing the options without the accompanying risk exposures. However, if their delta hedging strategies are based on the incorrect pricing formulation that do

not take into account the presence of coskewness during periods of crisis, the potential losses can be significant, as shown in this paper. This has important implications for market participants engaged in the hedging of financial risks and for financial regulators seeking to manage risks across the financial institutions. Mispricing of assets during periods of financial crisis and contagion could have systematic implications for the financial stability of the economies.

The key implication of the results of the paper is the importance of pricing higher order moments, especially during financial crises. Option prices based on Black-Scholes assumptions, and in particular, multivariate normality, can result in significant mispricing of options. The paper provided one strategy for embedding higher order moments into the calculation of option prices, but alternative strategies also exist as well. Moreover, the paper showed the importance of pricing the risks of higher order moments to minimize the exposure of portfolios to price movements in market during financial crises. Whilst this analysis was conducted through the construction of delta-hedged portfolios, the analysis suggested the importance of expanding the set of Greek hedging parameters to include hedging strategies that explicitly take into account higher order moment behavior of returns, including Greeks that capture coskewness and cokurtosis. An alternative approach is to construct a dynamic hedge under various scenarios including an allowance for higher order moments in the returns generating process as well as allowing for varying rebalancing frequencies.

References

- [1] Aït-Sahalia, Y., Cacho-Diaz, J. and Laeven, R. (2010), “Modeling Financial Contagion Using Mutually Exciting Processes”, NBER Working Paper No w15850.
- [2] Aït-Sahalia, Y., Wang, Y. and Yared, F. (2001), “Do Option Markets Correctly Price the Probabilities of Movement of the Underlying Asset?”, *Journal of Econometrics*, 102, 67-110.

- [3] Ane, T. (1999), “Pricing and Hedging S&P500 Options with Hermite Polynomial Approximation: Empirical Tests of Madan and Milne’s Model”, *Journal of Futures Markets*, 19, 735-758.
- [4] Bae, K.H., Karolyi, G.A. and Stulz, R.M. (2003), “A New Approach to Measuring Financial Contagion”, *Review of Financial Studies*, 16, 717-763.
- [5] Boyle, P.P. (1977), “Options: A Monte Carlo Approach”, *Journal of Financial Economics*, 4, 323-338.
- [6] Busetti, F and Harvey, A.C. (2011), “When is a Copula Constant? A Test for Changing Relationships”, *Journal of Financial Econometrics*, 9, 106-131.
- [7] Corrado, C.J. and Su, T. (1997), “Implied Volatility Skews and Stock Index Skewness and Kurtosis implied by S&P 500 index Option Prices”, *Journal of Derivatives*, Summer, 8-19.
- [8] Cox J.C., and Ross, S.A. (1976), “The Valuation of Options for Alternative Stochastic Processes”, *Journal of Financial Economics*, 3, 145-166.
- [9] Cox, J.C., and Ross, S.A., Rubinstein, M. (1979), “Option Pricing: A Simplified Approach”, *Journal of Financial Economics*, 7, 229-263.
- [10] Cheang, G.H.L., and Chiarella, C. (2008), “Exchange Options under Jump-Diffusion Dynamics”, *Quantitative Finance Research Centre*, Research Paper No. 235.
- [11] Dungey, M., Fry, R.A., González-Hermosillo, B. and Martin, V.L. (2010), *Transmission of Financial Crises and Contagion: A Latent Factor Approach*, Oxford University Press.
- [12] Favero, C.A. and Giavazzi, F. (2002), “Is the International Propagation of Financial Shocks Non-linear? Evidence from the ERM”, *Journal of International Economics*, 57, 231-246.
- [13] Fry, R.A., Martin, V.L., and Tang, C. (2010), “A New Class of Tests of Contagion with Applications”, *Journal of Business and Economic Statistics*, 28, 423-437.
- [14] Garcia, R. and Gencay, R. (2000), “Pricing and Hedging Derivative Securities with Neural Networks and a Homogeneity Hint”, *Journal of Econometrics*, 94, 93-115.

- [15] Harvey, A.C. (2010), "Tracking a Changing Copula", *Journal of Empirical Finance*, 17, 485-500.
- [16] Hull, J. (2000), *Options, Futures and Other Derivatives*, Upper Saddle River, NJ: Prentice-Hall, Fourth Edition.
- [17] Jarrow, R. and Rudd, A. (1982), "Approximate Option Valuation for Arbitrary Stochastic Processes", *Journal of Financial Economics*, 10, 347-369.
- [18] Lim, G.C., Lye, J.N., Martin, G.M. and Martin, V.L. (1998), "The Distribution of Exchange Rate Returns and the Pricing of Currency Options", *Journal of International Economics*, 45, 351-368.
- [19] Lim, G.C., Martin, G.M. and Martin, V.L. (2006), "Pricing Currency Options in the Presence of Time-Varying Volatility and Non-normalities", *Journal of Multi-national Financial Management*, 16, 291-314.
- [20] Lim, G.C., Martin, G.M. and Martin, V.L. (2005), "Parametric Pricing of Higher Order Moments in S&P500 Options", *Journal of Applied Econometrics*, 20, 377-404.
- [21] Flynn, D.B., Grose, S.D., Martin, G.M. and Martin, V.L. (2005), "Pricing Australian S&P200 Options: A Bayesian Approach Based on Generalized Distributional Forms", *Australian and New Zealand Journal of Statistics*, 47, 101-117.
- [22] Margrabe, W. (1978), "The Value of An Option to Exchange One Asset for Another", *The Journal of Finance* , 33, 177-186.
- [23] Martin, V.L. and Wang, J. (2013), "A Conditional Copula Test of Contagion", mimeo.
- [24] Martin, G.M., Forbes, C.S. and Martin, V.L. (2005), "Implicit Bayesian Inference Using Option Prices", *Journal of Time Series Analysis*, 26, 437-462.
- [25] Melick, W.R. and Thomas, C.P. (1997), "Recovering an Asset's Implied PDF from Option Prices: An Application to Crude Oil During the Gulf Crisis", *Journal of Financial Quantitative Analysis*, 32, 91-115.
- [26] Patton, A. (2006), "Modelling Asymmetric Exchange Rate Dependence", *International Economic Review*, 47, 527-556.

- [27] Pesaran, H. and Pick, A. (2007), “Econometric Issues in the Analysis of Contagion”, *Journal of Economic Dynamics and Control*, 31, 1245-1277.
- [28] Rodriguez, J.C. (2007), “Measuring Financial Contagion: A Copula Approach”, *Journal of Empirical Finance*, 14, 401-423.

A Appendix: Derivation of Deltas for An Exchange Option

From equation (3), the price of a European exchange option at time t to exchange asset 2 for asset 1 at time T , is

$$C_t^{BS} = P_{1,t} \exp(-q_1(T-t))N(d_1) - P_{2,t} \exp(-q_2(T-t))N(d_2),$$

where $P_{1,t}$ and $P_{2,t}$ are the underlying asset prices of assets 1 and 2 respectively, q_1 and q_2 are the respective dividend yields and

$$d_1 = \frac{\ln(P_{1,t}/P_{2,t}) + (q_2 - q_1 + \sigma^2/2)(T-t)}{\sigma\sqrt{(T-t)}},$$

$$d_2 = d_1 - \sigma\sqrt{T-t},$$

with $N(\cdot)$ representing the cumulative probability density function of a variable that is normally distributed with zero mean and a standard deviation of one, and

$$\sigma = \sqrt{\sigma_1^2 + \sigma_2^2 - 2\rho\sigma_1\sigma_2},$$

where σ_1 and σ_2 are the volatility rates of assets 1 and 2 respectively and ρ measures the correlation between the two assets.

The partial derivatives of d_1 and d_2 with respect to $P_{1,t}$ are

$$\frac{\partial d_1}{\partial P_{1,t}} = \frac{1}{\sigma\sqrt{(T-t)}} \left(\frac{1}{\frac{1}{P_{2,t}}P_{1,t}} \right) \left(\frac{1}{P_{2,t}} \right) = \frac{1}{\sigma\sqrt{(T-t)}P_{1,t}},$$

and

$$\frac{\partial d_2}{\partial P_{1,t}} = \frac{1}{\sigma\sqrt{(T-t)}P_{1,t}},$$

respectively. It follows that

$$\frac{\partial d_1}{\partial P_{1,t}} = \frac{\partial d_2}{\partial P_{1,t}}. \tag{26}$$

Now, an expression which links d_1^2 and d_2^2 may be derived from equation (5), with d_1 in the second line of derivation below substituted by equation (4)

$$\begin{aligned}
d_2^2 &= \left(d_1 - \sigma \sqrt{(T-t)} \right)^2 \\
&= d_1^2 + \sigma^2 (T-t) - 2d_1 \sigma \sqrt{(T-t)}, \\
&= d_1^2 + \sigma^2 (T-t) - 2\sigma \left[\frac{\ln(P_{1,t}/P_{2,t}) + (q_2 - q_1 + \sigma^2/2)(T-t)}{\sigma \sqrt{(T-t)}} \right] \sqrt{(T-t)}, \\
&= d_1^2 - 2 \ln(P_{1,t}/P_{2,t}) - 2(q_2 - q_1)(T-t). \tag{27}
\end{aligned}$$

Using the relationship between d_1^2 and d_2^2 , the relationship between the normal density functions of the variables d_1 and d_2 can be derived. The normal density functions of d_1 and d_2 are given by

$$n(d_1) = \frac{1}{\sqrt{2\pi}} \exp(-d_1^2/2), \tag{28}$$

and

$$n(d_2) = \frac{1}{\sqrt{2\pi}} \exp(-d_2^2/2), \tag{29}$$

respectively.

Substituting the expression linking d_1^2 and d_2^2 into equation (29) yields the following

$$\begin{aligned}
n(d_2) &= \frac{1}{\sqrt{2\pi}} \exp\left(\frac{-[d_1^2 - 2 \ln(P_{1,t}/P_{2,t}) - 2(q_2 - q_1)(T-t)]}{2} \right), \\
&= \frac{1}{\sqrt{2\pi}} \exp(-d_1^2/2) \exp[\ln(P_{1,t}/P_{2,t}) + (q_2 - q_1)(T-t)],
\end{aligned}$$

which is expressed simply as

$$n(d_2) = n(d_1) \exp[\ln(P_{1,t}/P_{2,t}) + (q_2 - q_1)(T-t)],$$

using equation (28). Upon further algebraic simplification, the equation for $n(d_2)$ becomes

$$n(d_2) = n(d_1) (P_{1,t}/P_{2,t}) \exp[(q_2 - q_1)(T-t)]. \tag{30}$$

Partially differentiating the valuation equation for the exchange option with respect to $P_{1,t}$ yields

$$\begin{aligned}
\frac{\partial C^{BS}}{\partial P_{1,t}} &= \exp(-q_1(T-t))N(d_1) + P_{1,t} \exp(-q_1(T-t)) \frac{\partial N(d_1)}{\partial P_{1,t}} \\
&\quad - P_{2,t} \exp(-q_2(T-t)) \frac{\partial N(d_2)}{\partial P_{1,t}}, \\
&= \exp(-q_1(T-t))N(d_1) + P_{1,t} \exp(-q_1(T-t))n(d_1) \frac{\partial d_1}{\partial P_{1,t}} \\
&\quad - P_{2,t} \exp(-q_2(T-t))n(d_2) \frac{\partial d_2}{\partial P_{1,t}}.
\end{aligned}$$

Substituting out $n(d_2)$ and $\frac{\partial d_2}{\partial P_{1,t}}$ using equations (30) and (26) respectively yields

$$\begin{aligned} \frac{\partial C^{BS}}{\partial P_{1,t}} &= \exp(-q_1(T-t))N(d_1) + P_{1,t} \exp(-q_1(T-t))n(d_1) \frac{\partial d_1}{\partial P_{1,t}} \\ &\quad - P_{2,t} \exp(-q_2(T-t)) \{n(d_1) (P_{1,t}/P_{2,t}) \exp[(q_2 - q_1)(T-t)]\} \frac{\partial d_1}{\partial P_{1,t}}, \end{aligned}$$

which ultimately simplifies to

$$\frac{\partial C^{BS}}{\partial P_{1,t}} = \exp(-q_1(T-t))N(d_1). \quad (31)$$

Equation (31) shows how the value of the exchange option varies with changes in the underlying asset value given by $P_{1,t}$. A similar expression can be derived which gives the sensitivity of the option value to changes in the other asset value given by $P_{2,t}$

$$\begin{aligned} \frac{\partial d_1}{\partial P_{2,t}} &= \frac{1}{\sigma \sqrt{(T-t)}} \left(\frac{1}{\frac{P_{1,t}}{P_{2,t}}} \right) \left(-\frac{P_{1,t}}{P_{2,t}^2} \right) = -\frac{1}{\sigma \sqrt{(T-t)} P_{2,t}}, \\ \frac{\partial d_2}{\partial P_{2,t}} &= \frac{\partial d_1}{\partial P_{2,t}} = -\frac{1}{\sigma \sqrt{(T-t)} P_{2,t}}. \end{aligned}$$

Using equations(28) and (27), an expression for $n(d_1)$ which provides a link to $n(d_2)$ is derived

$$n(d_1) = n(d_2) \left(\frac{P_{2,t}}{P_{1,t}} \right) \exp[-(q_2 - q_1)(T-t)]. \quad (32)$$

Partially differentiating the valuation equation for the exchange option with respect to $P_{2,t}$ yields

$$\begin{aligned} \frac{\partial C^{BS}}{\partial P_{2,t}} &= P_{1,t} \exp(-q_1(T-t)) \frac{\partial N(d_1)}{\partial P_{2,t}} \\ &\quad - \left[P_{2,t} \exp(-q_2(T-t)) \frac{\partial N(d_2)}{\partial P_{2,t}} + \exp(-q_2(T-t))N(d_2) \right], \\ &= P_{1,t} \exp(-q_1(T-t))n(d_1) \frac{\partial d_1}{\partial P_{2,t}} \\ &\quad - P_{2,t} \exp(-q_2(T-t))n(d_2) \frac{\partial d_2}{\partial P_{2,t}} - \exp(-q_2(T-t))N(d_2). \end{aligned}$$

Substituting out $n(d_1)$ and $\frac{\partial d_1}{\partial P_{1,t}}$ using equations (32) and (26) respectively yields

$$\begin{aligned} \frac{\partial C^{BS}}{\partial P_{2,t}} &= P_{1,t} \exp(-q_1(T-t)) \left[n(d_2) \left(\frac{P_{2,t}}{P_{1,t}} \right) \exp[-(q_2 - q_1)(T-t)] \right] \frac{\partial d_2}{\partial P_{2,t}} \\ &\quad - P_{2,t} \exp(-q_2(T-t))n(d_2) \frac{\partial d_2}{\partial P_{2,t}} - \exp(-q_2(T-t))N(d_2), \end{aligned}$$

which upon rearranging becomes

$$\frac{\partial C^{BS}}{\partial P_{2,t}} = -\exp(-q_2(T-t))N(d_2). \quad (33)$$

Equation (33) provides the change in the exchange option value with respect to a change in the value of the other underlying asset $P_{2,t}$.